

Minute Man Anchors

"Specializing in Anchoring Earth Bound Objects"



Installation Instructions

For Anchors, Frame Ties, Steel Piers, & LLBS Support Systems

305 West King St.
East Flat Rock, North Carolina 28726





LIMITED WARRANTY

Minute Man Anchors warrants its product is free from defects in materials and workmanship at the time of installation when properly installed in accordance with the installation instructions. THE FOREGOING WARRANTY IS IN LIEU OF ANY OTHER WARRANTY, WHETHER EXPRESS OR IMPLIED, WRITTEN OR ORAL, INCLUDING ANY WARRANTY OF MERCHANTABILITY OR FITNESS FOR A PARTICULAR PURPOSE. ANY LIABILITY IS EXPRESSLY LIMITED TO AN AMOUNT EQUAL TO THE PURCHASE PRICE PAID, AND ALL CLAIMS FOR SPECIAL, INCIDENTAL AND CONSEQUENTIAL DAMAGES ARE HEREBY EXCLUDED. Minute Man does not assume any other liability or obligation in connection with the sale or use of this product.

If the product is defective at the time of delivery or installation and you give prompt notice to Minute Man no later than thirty [30] days of attempted installation of the defect, Minute Man, at its option, will replace the product at no cost or refund the full amount of the purchase price, provided The defective product is returned to Minute Man with proof of purchase at the address set forth below. PRODUCT REPLACEMENT OR REFUND IS YOUR SOLE AND EXCLUSIVE REMEDY.

This warranty extends only to the distributor and original installer of the product and does not cover a defect resulting from abuse, misuse, neglect, repairs, any use not in conformity with The printed instructions or installation by unauthorized personnel.

This warranty gives you specific legal rights, and you may also have other legal rights which vary from state to state. Some states do not allow limitations on implied warranties or special, incidental or consequential damages, so the foregoing limitations may not apply to you.

If you have a claim under this warranty, please contact our CUSTOMER SERVICE department (have make, model numbers and soil class numbers):

CUSTOMER SERVICE
Toll Free in the U.S. 1-800-438-7277
1-828-692-0256

OR WRITE TO:
Minute Man- Customer Service
305 West King Street
East Flat Rock, NC 28726

To our knowledge, the information provided in and by the independent, professional engineers' reports and certifications and obtained from other independent sources contained in the installation instructions and product manuals is accurate. However, Minute Man Anchors cannot assume any liability whatsoever for the accuracy or completeness thereof. Final determination of the suitability of any information or material for the use contemplated is the sole responsibility of the user. Specifications are subject to change without notice. The load ratings established in the report are not valid in any application where the use of the product would overload any structural member of the home or foundation, or would invalidate the written limited warranty, or would violate any applicable building code or these installation standard or instructions.

To Our Customers:

These Installation Instructions are provided as a source of reference and installation information.

Minute Man Anchors, having pioneered anchoring for the manufactured home industry, continues in our efforts to provide new and innovative products. In so doing, we are committed to the highest quality made materials, workmanship and total customer satisfaction.

If you are a longtime Minute Man customer, "Thank You" for your continued trust and patronage. If you are a new customer, "Welcome!" we look forward to serving you in this ever growing industry.

Questions?

Regardless of your level of association with the Manufactured Housing market, if you have questions or we may be of service, please contact our office.

1-800-438-7277

FAX: (828) 692-0258

You can also find further information at our website:

www.minutemanproducts.com

Table of Contents

Installation	1
Strap Tensioner	1
Stabilizer	2
Frame Tie to Anchor	2
Frame Tie Instructions	3
Locking Frame Clamp II	3
EZ Anchor Installation.....	4
GW-2 Anchor Installation.....	5
Cross Drive.....	6
EZ Joist Brace	6
Mobile Home Pier Installation Instructions	7
Concrete Anchor Installation Instructions	8
HUD Soil Classification Chart.....	9
Wind Zone Chart	9
MMA Soil Classification Chart/Soil Probe Instructions	10
Product Description	11-12
Approval letter	13
RADCO Listing #1344	14-15
RADCO Listing #1350	16
RADCO Listing #1355	17-18
West Coast Approval	19-20
Longitudinal Lateral Bracing System	21
Strap Crimping.....	22
Water Level Instructions	23

*Note: Prior to installation, refer to any local, state and federal regulations, to assure proper compliance.
Soil test probe the anchor location in order to match the soil classification with the proper anchor.*

Note: Prior to installation, refer to any local, state and federal regulations, to assure proper compliance. Soil test probe the anchor location in order to match the soil classification with the proper anchor.



Minute Man Anchors

"Specializing in Anchoring Earth Bound Objects"

ANCHOR INSTALLATION

There are two basic methods of installing anchors, each equally effective in properly securing manufactured homes to the ground.

CAUTION: The installation of anchors with a drive machine is a two person operation.

Warning: Before ground anchor installation, determine that the anchor locations around home will not be close to any underground electrical cables, water lines or sewer piping. Failure to determine the location of electrical cables may result in serious personal injury.

MACHINE INSTALLATION

In this method, the anchor is turned to full depth into the ground by an anchor drive machine.

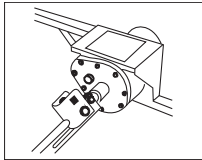
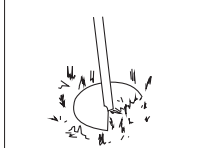
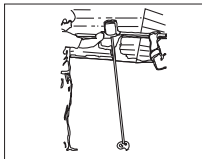
1.  Attach anchor to machine.
2.  Placed anchor in proper position in line with strap and machine.
3.  Anchor should be installed at a slight angle as shown to assure head being positioned behind future skirting.

MANUAL INSTALLATION

A hole is dug to a depth of approximately $\frac{1}{2}$ the length of the anchor, in the proper position as explained under machine installation.



After the hole is dug to $\frac{1}{2}$ the length of the anchor, then the anchor is turned into the ground by hand, using a rod or length of pipe for leverage or by machine.

After anchor is installed full depth, earth is repacked, six inches at a time.

PROPER TENSIONING OF STRAP TO ANCHOR HEAD

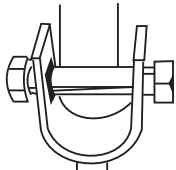
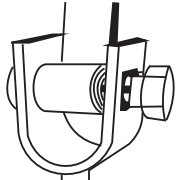
1.  Insert bolt into head; attach nut loosely. Insert strap in slot of $\frac{5}{8}$ " bolt until strap is flush with far side of bolt.
2.  Bend strap 90° and take at least three complete turns on bolt until strap is taut.

3. Bolt is turned with $\frac{15}{16}$ " socket wrench, or adjustable wrench, on hex head. With square hole in anchor head, hold bolt under tension while repositioning wrench: Place open-end wrench on $\frac{5}{8}$ " square shoulders of bolt. Align square shoulders of bolt with square hole in anchor head.

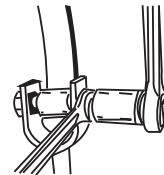

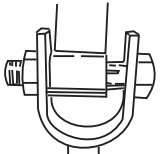
4.  Holding hex head of bolt in position, tighten nut to draw square shoulders into square hole. Shoulders are now in locking position; continue to tighten nut. Tensioning device is now in locked, secure position.

Note: The tensioning bolt can be inserted in the head from either side.

Notice: In areas of severe cold weather, where possible damage could occur from frost heave, the homeowner should be prepared to adjust tension on the straps to take up slack.

MINUTE MAN ANCHORS

INSTRUCTION FOR USING MINUTE MAN STABILIZING DEVICE

Minute Man stabilizing devices are designed for use with Minute Man anchors and intended to laterally restrict movement of the anchor through the soil.

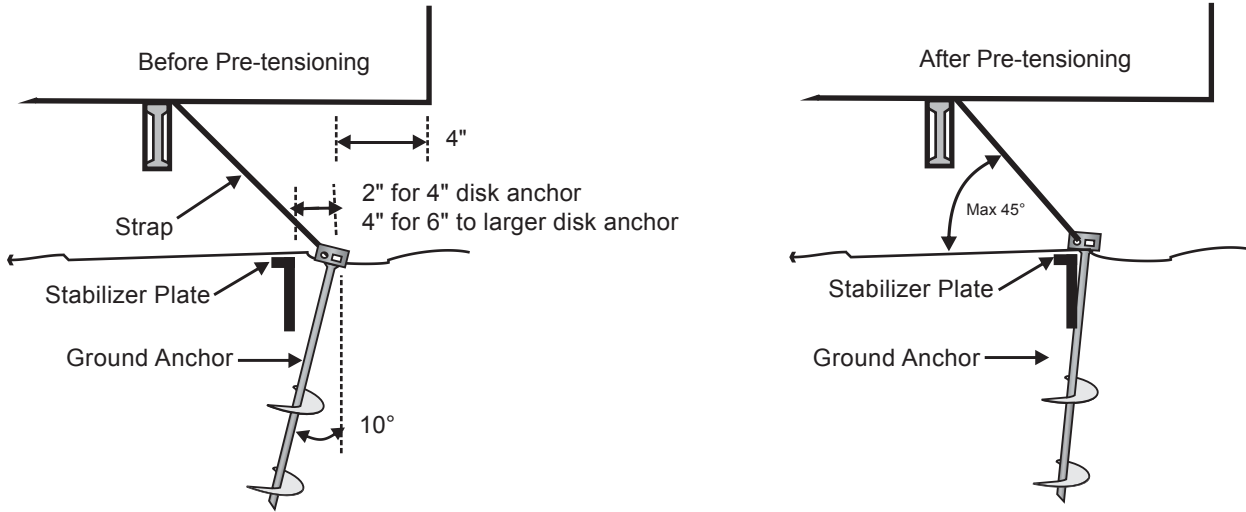

1. Place the anchors approximately four inches to the inside of the exterior wall line of the home or a sufficient distance to avoid interference with the skirting (see above)
2. Hold the anchor at an angle of approximately 10 degrees off of vertical so that the head of the anchor is just outside the sidewall (see above)
3. Install the anchor to a depth of approximately one-third (1/3) the anchor length.
4. Place a stabilizer plate to the inside of the anchor shaft (side of shaft toward center of house) and the distance indicated from the shaft.
5. Drive the stabilizer plate into the ground until the top of the plate is 1" below the surface of the ground.
6. Install the anchor to its full depth.
7. Pretension the anchor by pulling it up to the stabilizer plate. Pull the anchor approximately 1/2 inch more while it is in contact with the plate using the strap and take-up bolt to move the anchor head.

FRAME TIE TO ANCHOR

Longitudinal Frame Tie To Anchor

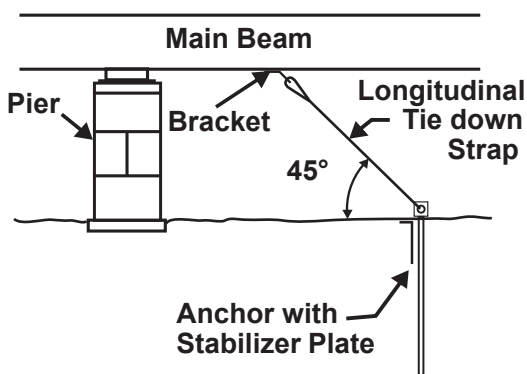

Lateral Frame Tie To Anchor

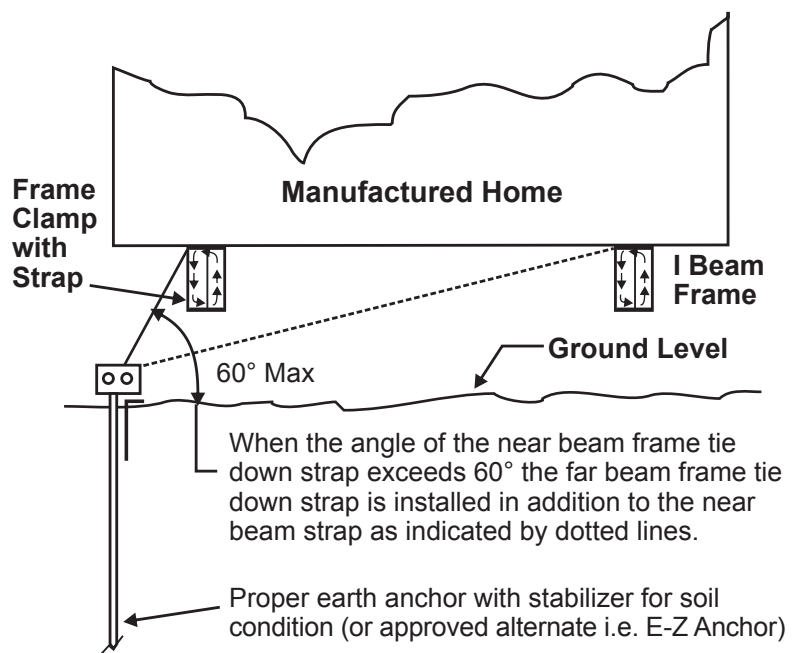

FRAME TIE INSTALLATION INSTRUCTIONS

Frame Tie With Buckle

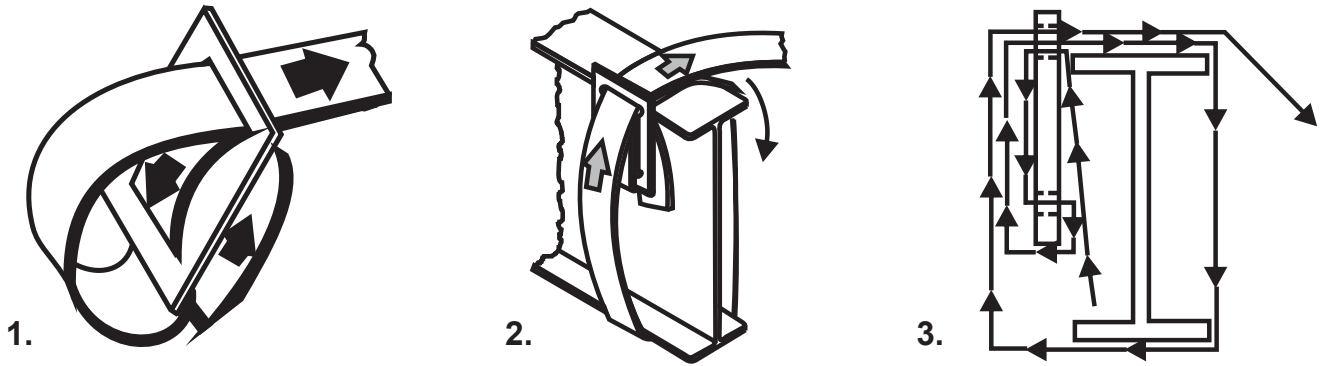

Thread sufficient length of frame tie strap through buckle as shown.

Next, thread long end of strap between frame and floor of home. Bring strap around frame and back through buckle as shown in diagram and fasten to anchor head.

Diagram showing strap in position around frame and through buckle. It is important to remove all slack from system.

Note: Use of a single buckle is an appropriate alternate.

Single Slot Buckle With Strap

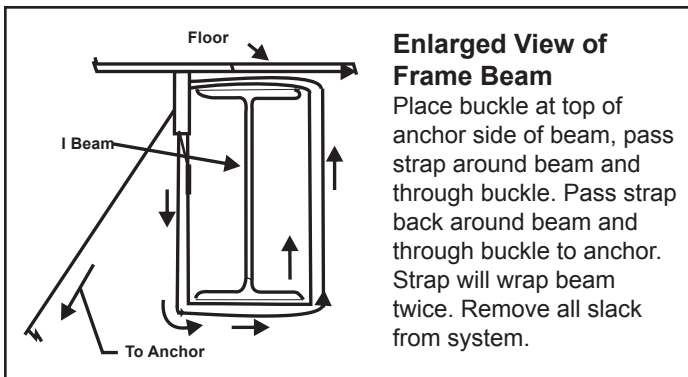

Frame Tie With Hook

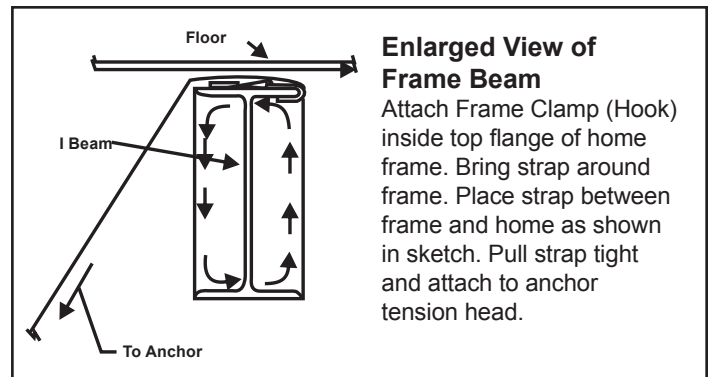

LOCKING FRAME CLAMP II MMA-33 ASSEMBLED UNIT

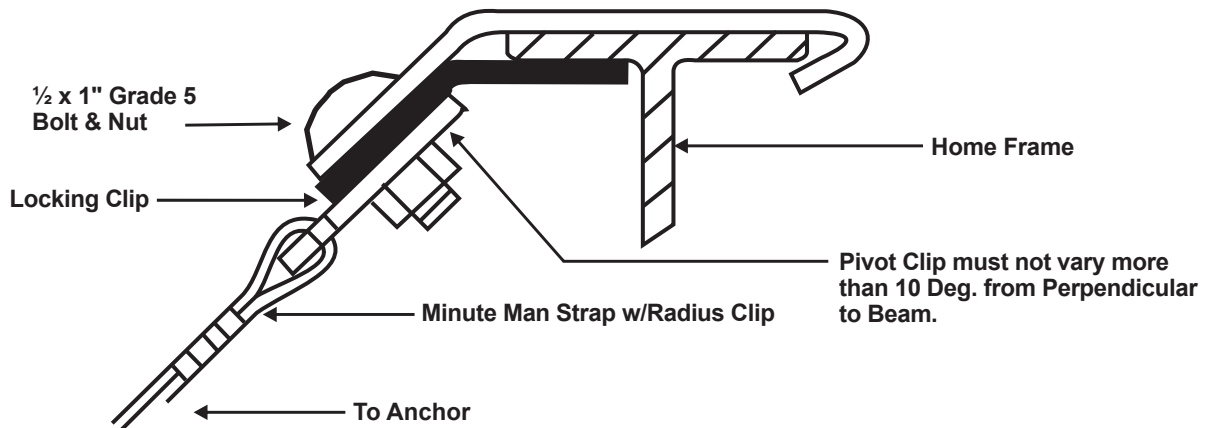

E-Z ANCHOR INSTALLATION METHOD

Note: With machine installation, a Minute Man adapter designed to fit both the anchor head and drive machine shaft is available. Installers do not need additional or special equipment for E-Z Anchor Installation.

E-Z Anchors are a patented item.

1. MACHINE INSTALLATION

The drive machine is started and the anchor is turned into the ground to a point where the top (stabilizer head plate) is flush with or slightly below ground level. This assures that the E-Z Anchor Stabilizer will be at its required installation position. **See Figure A.**

To achieve full potential, install the E-Z Anchor vertically. A 10° deviation from vertical is acceptable. **See Figure A.**

Note: A slightly greater angle may be used to start anchor to avoid contact with the home and straightened as anchor is ground set. The split bolt is inserted, strap is fastened, and tightening adjustment made.

E-Z Anchor carries U.S. Patents and manufacture is exclusive to Minute Man Anchors.

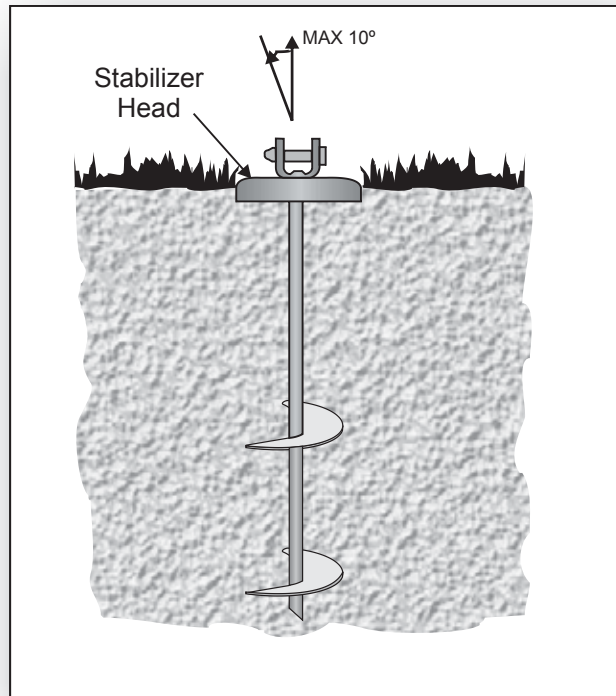

Figure A

2. STANDARDS FOR INSTALLATION

- E-Z Anchors and all components are to be installed per manufacturer's instructions.
- E-Z Anchors are approved for designated Soil Class III, IV.
- E-Z Anchor working load capacity is 3,150 pounds for a single tie or the load of (2) ties combined. **See Figure B.**
- Consult manufactured home set up instructions for number of frame tie downs, over the roof tie downs and tie down spacing.
- Proper site preparation requires removal of grass and sod prior to installation.

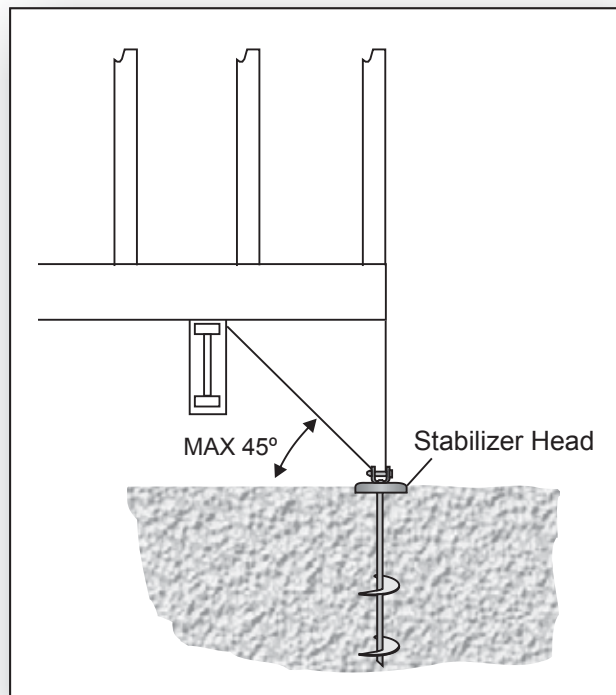

Figure B

For additional information, copies of engineering test(s) and report, Contact Minute Man Anchors.

GW-2 NU CONCEPT ANCHOR

INSTALLATION

CLASS 2+3

Patent # 6,871,455

The Nu-Concept GW-2 Anchor combines a patented elongated hole in the tension head with a stabilizing and compaction cap with drive rod guides. When combined with a grade 5 bolt, the anchor will rotate in all directions allowing adjustment to uneven terrain. Under load conditions the cap, rotates down ward in the direction of the pull, causing a double compaction of the soil and laterally restricts movement of anchor through the soil. Turn cap to position the drive rod guides facing away from the home. Insert 30" rods and drive to full depth into the soil.

- I. Attach stabilizer/compaction cap to the tension head of the anchor. This is done by sliding the cap over the top of the tension head, aligning 9/32" holes in cap with 1/4" elongated hole in tension head. Insert 1/4" x 2-1/4", grade 5 bolt (included). Hand tighten. Cap must be installed at any time prior to ground contact. See Cap *Figure A* and Tension Head *Figure B*.

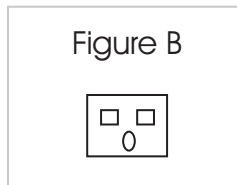
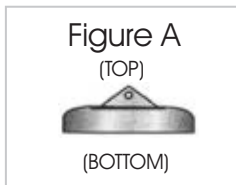

- II. The Drive Machine is started and the anchor is turned into the ground to a point where the bottom of the tension head is at or slightly below ground level. At this point the drive rod guides on the top of the cap should be slanted away from the outer wall of the home allowing the installer to drive the rods from the outside of the home. This insures maximum soil compression by the cap. See *Figure C*. Engineered to allow ground anchor to be installed at a slight back angle of 15°.

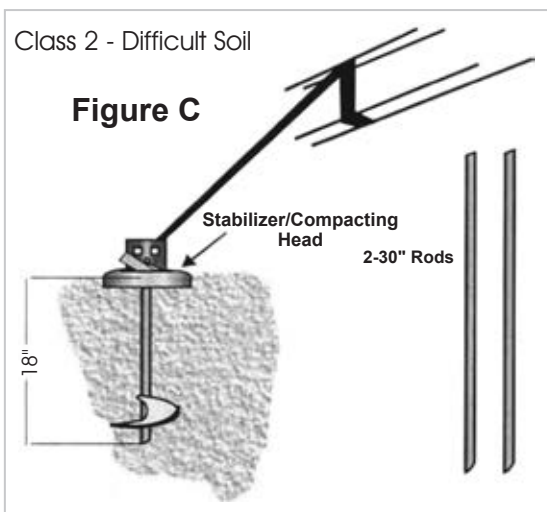

- III. Anchor is pre-loaded. Pre-load causes the cap to rotate downward in the direction of pull, further compacting the soil and presenting a larger surface area, resisting both horizontal and vertical movement. See *Figure D*. When used with rigid support tubes, rather than strap systems, pre-loading is not required.

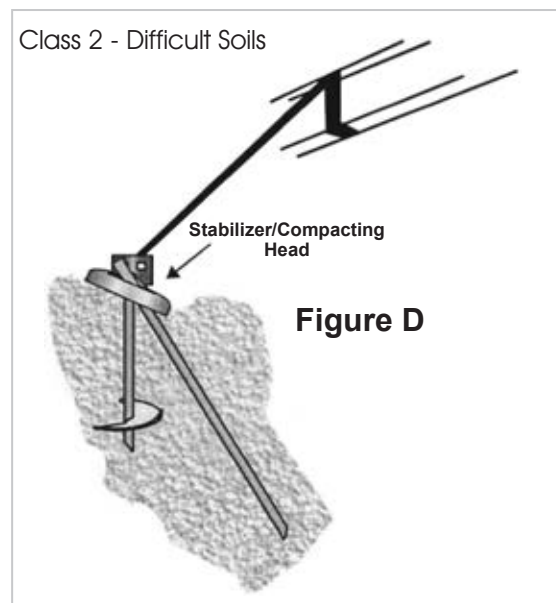

Note: A special adapter is available to insure against tension head and bolt damage.

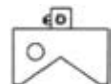

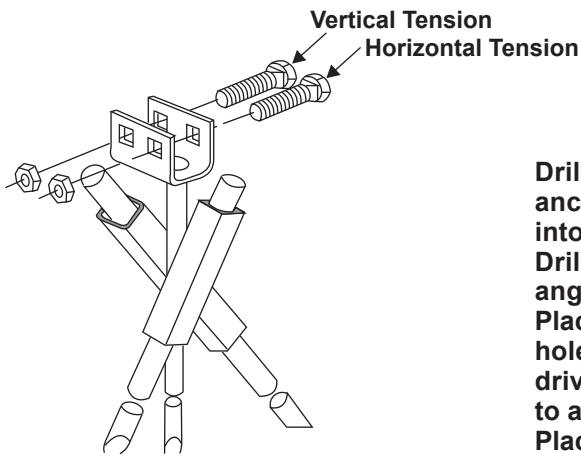

Installation Instructions for Cross Drive Rock Anchor

INSTALLATION INSTRUCTIONS

Drill 5/8" diameter hole 5 1/2" deep, in center of anchor location, for pilot stud. Insert pilot stud into hole.
 Drill two - 3/4" diameter holes in rock at 45 degree angles, using anchor head as a locating guide.
 Place rod through top of (1) square tube and into hole. Drive rod to desired depth. (Rod must be driven into rock at least 80% of its length in order to achieve minimum allowable pullout resistance.)
 Place second rod through top of remaining tube. Drive rod to desired depth to lock.
 Maximum pullout resistance is developed when anchor head is low as possible and ground surface is solid rock. Distance from square tubing to rock surface should not exceed 1".

New Minute Man EZ Joist Brace

- Ideal for supporting sticky doors and windows, heavy pianos, fish tanks, or water beds.
- EZ to install, one adjustable size fits most homes.
- Will not bend I-beams or split rim joist like outriggers can do.
- Braces from the ground up to the rim joist for stronger and more stable support under the home.

INSTALLATION INSTRUCTIONS

NOTE: Do not use the EZ Joist Brace to replace any foundation piers required by the home manufacturer. EZ Joist Braces' maximum working load is 2,200 lbs.

1. Determine the rim joist area that needs bracing.
2. Remove turf to expose firm soil at each EZ Joist Brace location. Footing must be level, directly under problem area, and located inside perimeter to allow clearance for skirting. Footings must be in compliance with home manufacturer, state codes, local codes, and frost line guidelines as they may apply.
3. Measure distance from top of footing to bottom of joist. Square cut top of tube 1" less than measured distance.
4. Turn nut on threaded rod up to "T" plate. Place "T" top into EZ Brace Joist Tube.
5. Center EZ Joist Brace under the rim joist and in the center of footing, use your level to be sure the brace is vertical.
6. Adjust nut on "T" top to apply desired pressure to level rim joist. Secure "T" top to rim joist with 2 - # 10 nails or 2 - # 10" x 2" screws in holes provided. **The maximum safe adjustment between the top of "T" top plate and top of tube is 2 1/2 inches.**

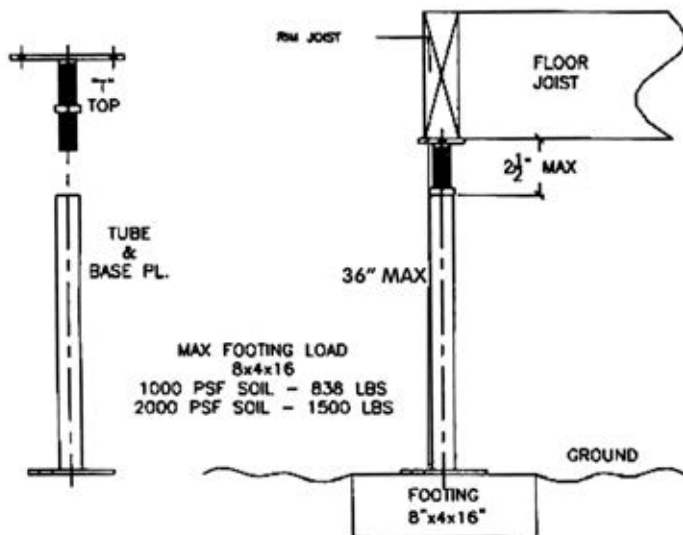

Minute Man Anchors

"Specializing in Anchoring Earth Bound Objects"

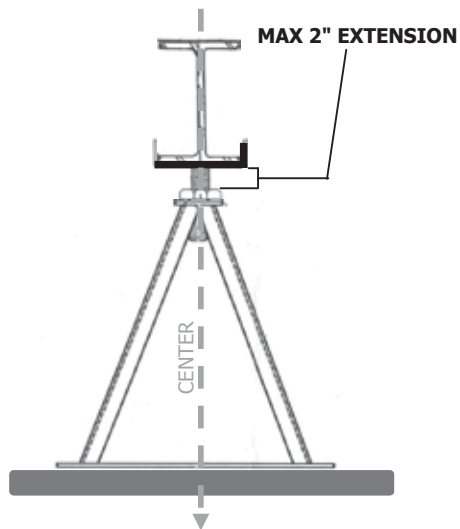

MINUTE MAN ANCHORS RADCO # 1350

RATED 6,000 POUNDS/2" MAX PIER HEAD EXTENSION
WARNING! DO NOT SET PIER DIRECTLY ON SOIL
DO NOT USE PIER AS AN AUTOMOTIVE JACK STAND

Foundation Pier Installation Instructions

For your safety read, understand, and follow the information provided with and on these foundation piers before installing. The manufactured unit shall be installed and leveled by qualified contracting personnel who are trained and licensed by the governing authority. Minute Man Foundation Piers are engineered to support on frame manufactured and modular homes and commercial modular structures. Foundation piers are designed and tested to vertical loads for a support rating of 6,000 lbs. (1 pier). Minute Man Foundation Piers should be placed directly under main support frames (I-beams). Design support configurations for pier loads, pier spacing, and live roof loads must be consistent with unit manufacturers installation guidelines (instructions) and/or State and local regulations. (HUD Code Part 3285.303,310).

FOUNDATION SET-UP PROCEDURES

1. The foundation pier is best suited to a dry environment and are not recommended for use within 1,500 feet of a coastline. All piers must be attached to the I-beams with a compatible pier head to prevent horizontal movement.
2. Refer to unit manufacturers installation instructions for proper leveling procedures before installing foundation piers. **Warning, no one should be under the unit while jacks are being operated or while the unit is supported only on the jacks. Be sure to use sufficient jacks, safety cribbing and blocking to safely support the home before installing piers. Piers should never be installed individually under a unit. A complete system of foundation piers must be set before the weight of the unit is lowered onto the piers. Failure to follow this step could result in serious injury or death.**
3. Determine the pier height that will be best for each individual pier location and insure that the height from the footer to the bottom of the chassis I-beam is no greater than 30 inches. Insure that the pier heads are compatible to I-beam chassis or for marriage line.
4. Each pier must be supported underneath with a compatible footer on a prepared level surface. Design support configurations for pier loads, pier spacing, and live loads must be consistent with unit manufacturer's installation guidelines (instructions) and/or State and local regulations (HUD Code Part 3285.303,310).
5. Center the pier on the footer. Where required by local code, secure the pier to the footer with appropriate fasteners. In no case should you extend the threaded rod of the pier head more than two inches. When more height is needed, use the next taller sized pier. Carefully align the support pier under the center of chassis beam or marriage line and install the pier head. Tighten and snug nut plus one-half turn.
6. Repeat the installation process with each pier. **After all foundation piers are installed properly you may remove the safety cribbing, blocking, and jacks used to initially level the unit.**

CONCRETE ANCHOR INSTALLATION INSTRUCTIONS

210 PDH CONCRETE ANCHOR

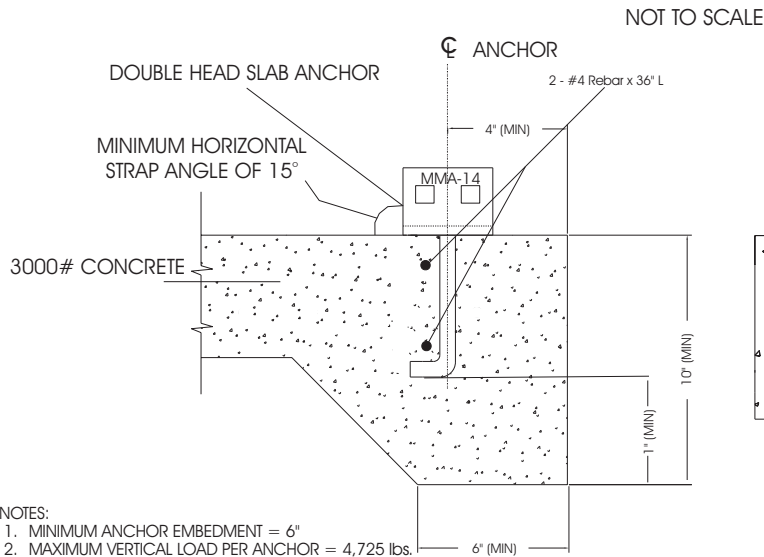

NOTES:

1. MINIMUM ANCHOR EMBEDMENT = 6"
2. MAXIMUM VERTICAL LOAD PER ANCHOR = 4,725 lbs. 3,150 lb. WORKING LOAD
3. MINIMUM SLAB PER ANCHOR:
4" SLAB = 95 S.F.
6" SLAB = 65 S.F.
8" SLAB = 48 S.F.
4. MARK: MMA-14

THDHLS CONCRETE ANCHOR

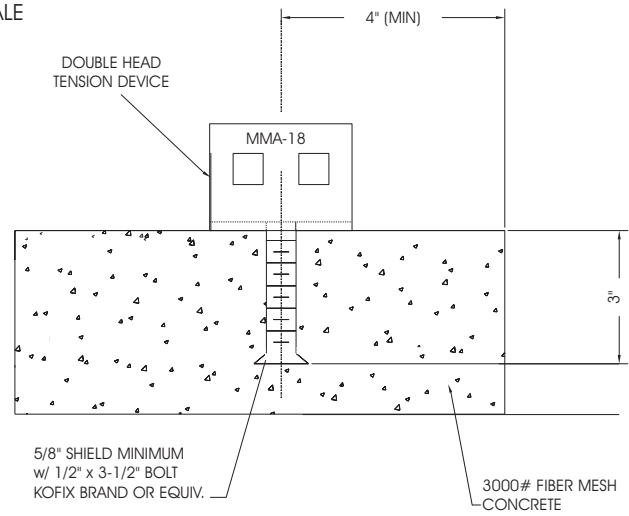

1. MAXIMUM VERTICAL LOAD PER ANCHOR = 4,725 lbs. 3,150 lbs. WORKING LOAD.
2. MINIMUM SLAB AREA PER BOLT
4" SLAB = 95 S.F.
6" SLAB = 65 S.F.
8" SLAB = 48 S.F.
3. MARK: MMA 18

INSTALLATION NOTE

1. DRILL 21/32" DIAM. HOLE 4" FROM EDGE OF SLAB AND INSERT SHIELD
2. PLACE TENSION HEAD ON SLAB AND INSTALL 1/2" DIAM. SHIELD BOLT



210 JDH CONCRETE ANCHOR

NOTE:

Your set must be designed by a Registered Professional Engineer if the location is within 1,500 feet of the coastline.

The allowable working load on concrete anchor models 210 PDH, THDHLS, and 210 JDH is 3,150 pounds vertical for single or double ties in 3,000 PSI concrete. There must be a minimum 4" of distance from the edge of the concrete to the center of the anchor shaft.

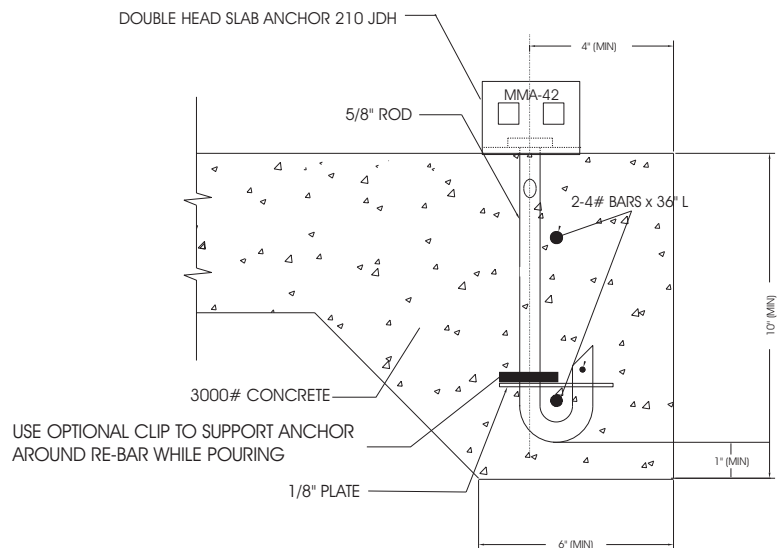

USE OPTIONAL CLIP TO SUPPORT ANCHOR AROUND RE-BAR WHILE POURING

1. MINIMUM ANCHOR EMBEDMENT = 6"
2. MAXIMUM LOAD PER ANCHOR = 4,725 lbs.
3. MINIMUM SLAB PER ANCHOR:
4" SLAB = 95 S.F.
6" SLAB = 65 S.F.
8" SLAB = 48 S.F.
4. MARK: MMA 42

Soil Classification and Bearing Capacity

TABLE TO § 3285.202

Soil classification		Soil description	Allowable soil bearing pressure (psf) ¹	Blow count ASTM D 1586-99	Torque probe ³ value ⁴ (inch-pounds)-
Classification number	ASTM D 2487-00 or D 2488-00 (incorporated by reference, see § 3285.4)				
1	Rock or hard pan	4000+		
2	GW, GP, SW, SP, GM, SM.	Sandy gravel and gravel; very than dense and/or cemented sands; coarse gravel/cobbles; preloaded silts, clays and coral.	2000	40+	More than 550.
3	GC, SC, ML, CL	Sand, silty sand; clayey sand; silty gravel; medium dense coarse sands; sandy gravel; and very stiff silt, sand clays.	1500	24-39	351-550.
4A	CG, MH ²	Loose to medium dense sands; firm to stiff clays and silts; alluvial fills.	1000	18-23	276-350.
4B	CH, MH ²	Loose sands; firm clays; alluvial fills	1000	12-17	175-275.
5	OL, OH, PT	Uncompacted fill; peat; organic clays	Refer to 3282.202(e)	0-11	Less than 175.

Notes:

¹ The values provided in this table have not been adjusted for overburden pressure, embedment depth, water table height, or settlement problems.

² For soils classified as CH or MH, without either torque probe values or blow count test results, selected anchors must be rated for a 4B soil.

³ The torque test probe is a device for measuring the torque value of soils to assist in evaluating the holding capacity of the soil in which the ground anchor is placed. The shaft must be of suitable length for the full depth of the ground anchor.

⁴ The torque value is a measure of the load resistance provided by the soil when subject to the turning or twisting force of the probe.

(f) If soil appears to be composed of peat, organic clays, or uncompacted fill, or appears to have unusual conditions, a registered professional geologist, registered professional engineer, or registered architect must determine the soil classification and maximum soil bearing capacity.

Source: Manufactured Home Construction and Safety Standards - Part 3285.202

DESIGN WIND-LOAD ZONES:

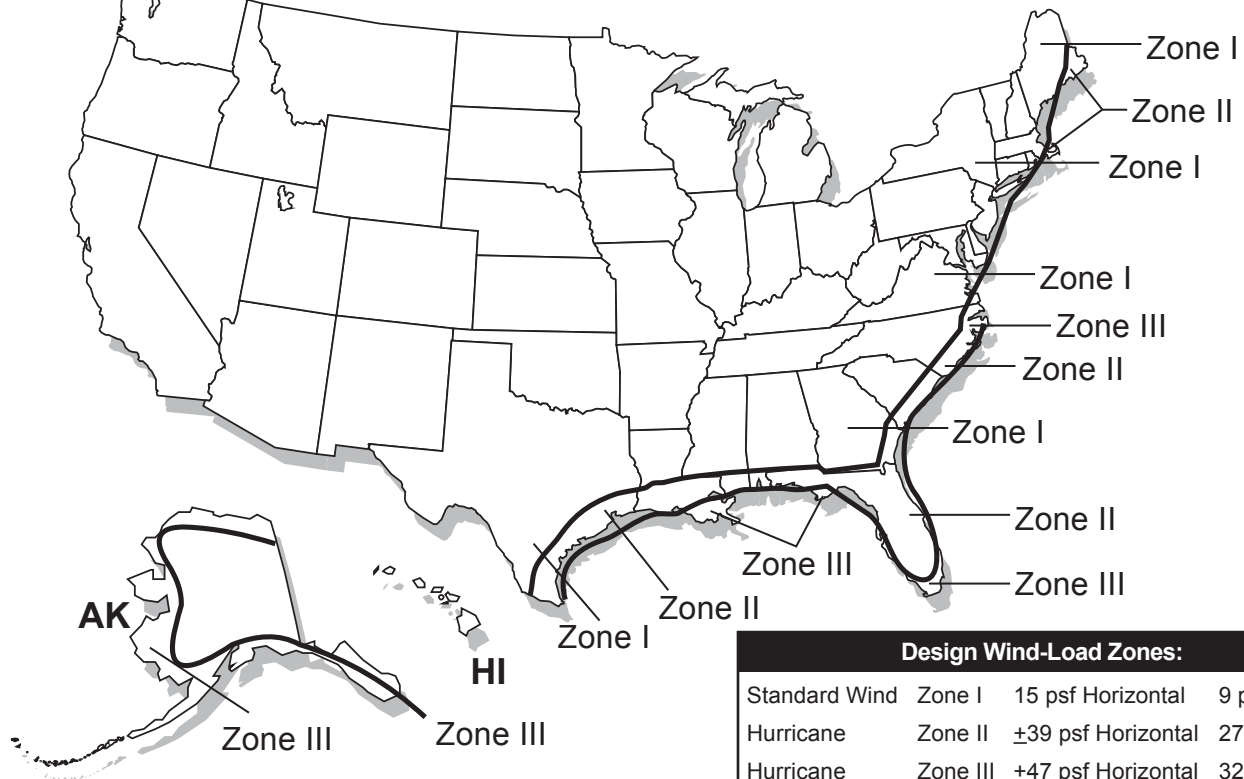

Design Wind-Load Zones:			
Standard Wind	Zone I	15 psf Horizontal	9 psf uplift*
Hurricane	Zone II	±39 psf Horizontal	27 psf uplift
Hurricane	Zone III	±47 psf Horizontal	32 psf uplift
			*net uplift
Note: psf: pounds per square foot			

Source: Manufactured Home Construction and Safety Standards- Part 3280.305

Note: Prior to installation, refer to any local, state and federal regulations, to assure proper compliance. Soil test probe the anchor location in order to match the soil classification with the proper anchor.

Soil Classification Chart

for Minute Man Anchors

Soil Class	Torque Probe Values	Recommended Minute Man Anchors & Stabilizers			
1	NA	Cross Drive or Rock Anchor			
2	551 Inch Pounds Up	4430 DH 4430 EZDH 12" Stabilizer Plate	4636 DH 4636 EZDH	636 DH 636 EZDH Nu-Concept Stabilizer Cap	4450 DH GW-2
3	351 to 550 Inch Pounds	4430 DH 4430 EZDH 12" Stabilizer Plate	4636 DH 4636 EZDH	636 DH 636 EZDH Nu-Concept Stabilizer Cap	4450 DH GW-2
4A	276 to 350 Inch Pounds	4636 DH 4636 EZDH	4450 DH 12" Stabilizer Plate	650 DH 17" Stabilizer Plate	
4B	175 to 275 Inch Pounds	760 DH 17" Stabilizer Plate	860 DH	1060 DH	
5	Less Than 175 Inch Pounds	Call Minute Man Anchors 800-438-7277			

Note:

Each state, county, municipality may require a specific anchor from the groups shown for each soil classification. Check local regulations before installation.

Test soil with soil probe and torque wrench at the anchor location in order to match the proper anchor with soil soil classification.

A stabilizer plate or certified stabilizing device must be used with DH anchors when the anchors are used to resist lateral loads.

Soil Test Probe and Torque Wrench

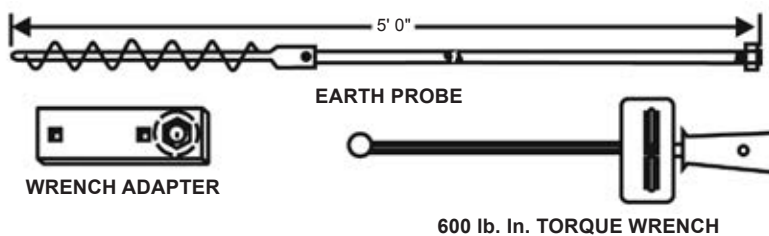

Warning: Before ground anchor installation or probing, determine that the anchor or probe locations around the home will not be close to any underground utilities. Failure to determine the location of electrical lines may result in serious personal injury.

Instructions

1. Place tip of probe into ground where the anchor is to be located. Using a 15/16" hex socket with a ratchet, breaker bar, or electric drive machine, turn soil probe in a clockwise direction.
2. Rotate probe into the soil to a depth equal to the length of the recommended anchor to be installed.
3. To determine the soil classification:
 - a) Place wrench adapter onto torque wrench.
 - b) Insert hex portion of wrench adapter onto the top of the probe.
 - c) Support probe shaft with one hand while turning the probe steadily with the torque wrench.
Do not exceed 600 inch pounds when turning!
 - d) Read torque value while turning torque wrench and probe clockwise.
 - e) Use Minute Man Anchors' Soil Classification Chart to cross reference probe readings and match the anchor model with the proper soil class at the site.

Following is a list of Minute Man Anchors with an allowable working load equal to or exceeding 3,150 lbs. and are capable of withstanding a 50% overload (4,725 lbs. total). Stabilizer devices must be used with anchors when anchors are used to resist horizontal forces. HUD Part 3280.506(f)



ITEM #	MARK	MODEL	DESCRIPTION	USE IN SOIL TYPE
1071	MMA-2	650-DH 5/8"	6" DISC, 50" ANCHOR	2,3,4(a)
1101	MMA-4	650-DH 3/4	6" DISC, 50" ANCHOR	2,3,4(a)
1131	MMA-28	636-DH 3/4	6" DISC, 36" ANCHOR	2,3
1241	MMA-30	4430-DH 5/8	DOUBLE 4" DISC, 30" ANCHOR	2,3
1271	MMA-6	4430-DH 3/4	DOUBLE 4" DISC, 30" ANCHOR	2,3
1349	MMA-35	36-XDH	36" CROSS DRIVE ANCHOR	1
1350	MMA-8	48-XDH	48" CROSS DRIVE ANCHOR	1
1390	MMA-BR	24 BA	BARB ROCK ANCHOR	1
1287	MMA-86	860-DH 3/4	8" DISC, 60" ANCHOR	4(b) (Fla.)
1288	MMA-71	1060-DH 3/4	10" DISC, 60" ANCHOR	4(b)
1291	MMA-75	760-DH 3/4	7" DISC, 60" ANCHOR	2,3,4(a),4(b)
1346	MMA-52	4636-DH 3/4	4" & 6" DISC, 36" ANCHOR	2,3,4(a)
1284	MMA-55	4450-DH 3/4	DOUBLE 4" DISC, 50" ANCHOR	2,3,4(a)
1592	MMA-92	4430-EZDH 3/4	DOUBLE 4" DISC, 30" EZ ANCHOR	2,3
1593	MMA-93	4636-EZDH 3/4	4" DISC, 6" DISC, 36" EZ ANCHOR	2,3,4
1594	MMA-94	636-EZDH 3/4	6" DISC, 36" EZ ANCHOR	2,3
1596	MMA-96	650-EZDH 3/4	6" DISC, 50" EZ ANCHOR	2,3
2390	MMA-18	THDH	DOUBLE HEAD TENSION DEVICE	SLAB
2391	MMA-18	THDHLS	DH TENSION DEVICE W/LAG	SLAB
1450	MMA-14	210-PDH	WET CONCRETE ANCHOR	SLAB
1445	MMA-42	210-JDH	SWIVEL HEAD WET CONCRETE ANCHOR	SLAB
1322	MMA	GW-2 -NC1	G W 2 SOIL ANCHOR	2,3
2200	MMA-SD2A		STABILIZER- 12"	2,3,4(a)
2202	MMA-SD2		STABILIZER- 17"	FLA. 2,3,4(a),4(b)
2211	N C1		NU CONCEPT STABILIZER CAP	2,3
2691	MMA-29	FCIWS	FRAME CLAMP II W/STRAP	FLA.
2820	MMA-31	FRAME TIE	LONGITUDINAL FRAME TIE-8 BOLT	
2822	MMA-34	FRAME TIE	LONGITUDINAL FRAME TIE-4 BOLT	
2700	MMA-32	BUC/WS	BUCKLE W/STRAP	
2801	MMA-33	FCII (LOCKING)	LOCKING FRAME CLAMP II	
2704	MMA-71	CT/WS	CORNER TIE W/STRAP	
2706	MMA-71-C	CT/WS	CORNER TIE W/STRAP	
2709	MMA-71-C	CT/WS	CORNER TIE W/ REG. STRAP	
2010	MMA	SBN	STRAP BOLT & NUT	

ITEM #	MARK	MODEL	DESCRIPTION	USE IN SOIL TYPE
2510 2530	MMA-25 MMA-32	22 BUCKLE SS BUCKLE	DOUBLE SLOT BUCKLE SINGLE SLOT BUCKLE	
2491 2492		44 RB 66 RB	4X4" ROOF BRACKET 6X6" ROOF BRACKET	
2150		POCKET PENETROMETER	POCKET PENETROMETER	
2100		SOIL TEST PROBE	SOIL TEST PROBE	
2250		JACKING PLATE	I BEAM JACKING PLATE	
3006 3008 3010 3012 3014 3016 3018 3020 3022 3024 3026 3028 3030 3521	MMP-6 MMP-8 MMP-10 MMP-12 MMP-14 MMP-16 MMP-18 MMP-20 MMP-22 MMP-24 MMP-26 MMP-28 MMP-30 MMSD3	6" PIER 8" PIER 10" PIER 12" PIER 14" PIER 16" PIER 18" PIER 20" PIER 22" PIER 24" PIER 26" PIER 28" PIER 30" PIER 20" STEEL PIER PAD	STANDARD MOBILE HOME PIER STANDARD MOBILE HOME PIER STANDARD MOBILE HOME PIER STANDARD MOBILE HOME PIER STANDARD MOBILE HOME PIER STANDARD MOBILE HOME PIER STANDARD MOBILE HOME PIER STANDARD MOBILE HOME PIER STANDARD MOBILE HOME PIER STANDARD MOBILE HOME PIER STANDARD MOBILE HOME PIER STANDARD MOBILE HOME PIER STANDARD MOBILE HOME PIER STANDARD MOBILE HOME PIER LONGITUDINAL & LATERAL BRACING SYSTEM	
LATERAL BRACE TUBES W/BEAM CLIP (For Soil Pier Pad)				
3532 3537	MMAST MMAST	60" LATERAL TUBE 72" LATERAL TUBE	LONGITUDINAL & LATERAL BRACING SYSTEM LONGITUDINAL & LATERAL BRACING SYSTEM	
LONGITUDINAL BRACE TUBES W/BEAM CLIP (For Soil Pier Pad)				
3539 3544 3553 3565	MMLBT MMLBT MMLBT MMLBT	20" STEEL PIER PAD 20" STEEL PIER PAD 20" STEEL PIER PAD 20" STEEL PIER PAD	LONGITUDINAL & LATERAL BRACING SYSTEM LONGITUDINAL & LATERAL BRACING SYSTEM LONGITUDINAL & LATERAL BRACING SYSTEM LONGITUDINAL & LATERAL BRACING SYSTEM	
LATERAL FLEX TUBES (For Concrete)				
3632 3637 3636	LFT2 LFT3	60" LAT FLEX TUBE 72" LAT FLEX TUBE "L" ANCHOR BOLT-WET SET	LONGITUDINAL & LATERAL BRACING SYSTEM LONGITUDINAL & LATERAL BRACING SYSTEM LONGITUDINAL & LATERAL BRACING SYSTEM	
LONGITUDINAL FLEX TUBES (For Concrete)				
3639 3644 3653 3632	LFT1 LFT1 LFT1 LFT1	39" LONG FLEX TUBE W/BC 44" LONG FLEX TUBE W/BC 53" LONG FLEX TUBE W/BC 65" LONG FLEX TUBE W/BC	LONGITUDINAL & LATERAL BRACING SYSTEM LONGITUDINAL & LATERAL BRACING SYSTEM LONGITUDINAL & LATERAL BRACING SYSTEM LONGITUDINAL & LATERAL BRACING SYSTEM	



ROD M. HUDGINS, JR. P.E.
P.O. BOX 5070
ASHEVILLE, N.C. 28813-5070

May 10, 2021

Rod M. Hudgins, Jr. P.E. – Principle

Minute Man Anchors
 305 West King Street
 East Flat Flock, NC 28726

Dear Sir,

I have analyzed design drawings, physical testing reports, and installation instructions for the Minute Man Anchor products listed as follows:

650 5/8 DH	4636 3/4 DH	THDH	Pivot Clip W/S
650 3/4 DH	4636 3/4 EZDH	THDH LS	FCII W/S
760 3/4 DH	4430 3/4 EZDH	210 JDH	BUC W/S
636 5/8 DH	4430 3/4 EZDH	210 PDH	MMA SD2
636 3/4 DH	636 3/4 EZDH	XDH	MMA SD2A
4450 3/4 DH	650 3/4 EZDH	24 BA	MMAS (Seal)
4430 5/8 DH	660 3/4 EZDH	36 XDH	SBN (Bolt & Nut)
4430 3/4 DH	GW 2-NC2	48 XDH	NC 2 (Stab. cap)

CT W/S Corner Tie MMA 71 & MMA 71C
 LLBS Longitudinal & Lateral Bracing System
 Asphalt Anchor 36X DH-working load 1,800 lbs.

Longitudinal Frame Tie MMA 31 & 34
 Locking FCII MMA 33
 2 Bolt Perimeter Frame Clamp

My analysis of the physical test reports defines the breaking strength of each of these anchors and their component to be in excess of 4,725 pounds. The strapping meets federal specifications QQ-S-781H for Type 1 class B, Grade 1 strapping. The strapping also meets with ANSI 225.1 standards and ASTM D3953-91 standards. The galvanized steel strapping is 1 1/4" x .035 minimum.

On file are testing reports of direct withdrawal strength of these anchors. These tests evaluate the anchorage strength of Minute Man Anchors installed resisting an axial and 45-degree angle applied withdrawal load. For the anchors listed on pages 10 and 11, the average holding power meets and / or exceeds the required minimum of 4,725 pounds when installed in accordance with manufacturer instructions in the soil type and class shown.

The LLBS Bracing System was tested for Wind Zones I, II, & III.



LISTING & TESTING DIVISION

PRODUCT: CONCRETE, ROCK, AND SOIL GROUND ANCHORS

Issued: Jan. 2014
Reissued: Jan. 2022

MANUFACTURER: Minute Man Anchors
305 W. King St.
East Flat Rock, NC 28726

Subject to Renewal:
January 2023

PLANT LOCATION: 305 W. King St.
East Flat Rock, NC 28726

APPLICATION: HUD Code Manufactured Homes, Modular Homes and Industrialized Commercial Structures

1. INTRODUCTION

At the request of Minute Man Anchors, RADCO has examined the Minute Man Ground Anchor designed to provide support for HUD Code Manufactured Homes, Modular Homes and Industrialized Commercial Structures for various soil bearing capacities.

2. DESCRIPTION

There are two categories of ground anchors that are specified in this listing. The first group is soil ground anchors, which pertain to all anchors designated for soil classes 2, 3, 4, and 5. The second group is rock and concrete (non-soil) ground anchors, which are designed for installation into class 1 conditions.

All Minute Man Ground Anchors are manufactured using steel in conformance with ASTM A-36. The models under this listing vary with respect to shaft diameter, number and location of helixes, length of shaft and stabilizer device. Table 1 shows a complete description of each ground anchor model, as well as a corresponding stabilizer device.

All ground anchors have a minimum working load of 3,150 lbs and a minimum ultimate load of 4,725 lbs.

3. INSTALLATION

The application of Minute Man Ground Anchors is for use on HUD code manufactured homes, modular homes and industrialized commercial structures in engineered foundation systems. The system shall be installed in accordance with the manufacturer's installation instructions and the requirements of this listing for maximum soil capacities as required by section 24 CFR § 3285.202 of the HUD Standards for Manufactured Housing, IRC Appendix E, Sections AE502, AE601, AE602, AE604 and AE605, to the IBC 2015 and 2018 for commercial use and section 1806.2. Soil Bearing Values. Other applicable Engineered Connections for Modular and Industrialized Building Systems which will not exceed the product designs and/or the local jurisdiction requirements.

The Installation of the ground anchors is to be in accordance with the Manufacturer's Installation Instructions. In addition, each anchor must be installed in accordance with the following:

- The proper soil class. (Tables 2 & 3, and notes)
- Minimum angle of pull to the horizontal. (Tables 2 & 3)

4. EVIDENCE SUBMITTED

- Testing has been conducted to verify the compliance of Minute Man ground anchors to the RADCO Listing Requirements for Ground Anchors.

- The quality and process control system used in the manufacture has been submitted to RADCO. An adequate method of traceability is maintained by the manufacturer. A follow-up quality assurance audit program is maintained by RADCO.

5. RECOMMENDATIONS

RADCO recommends that Minute Man Anchors ground anchors be accepted for use with HUD code manufactured homes, modular homes, industrialized commercial structures in engineered foundation systems provided that:

- Each ground anchor will be marked with a label, a facsimile of which is shown in figure 1. The label for each facility denotes the model number, RADCO name and Listing #1344.
- All products are produced only at the facility referenced in this listing.
- The Quality control procedures are maintained by the manufacturing facility as submitted.
- The manufacturing audit system of RADCO is maintained.
- All products are installed per the manufacturers installation instructions and section 3 of this listing.

6. APPROVAL

This listing is subject to approval on an annual basis by RADCO.

All products shall be identified as follows:

Figure 1: Sample Label

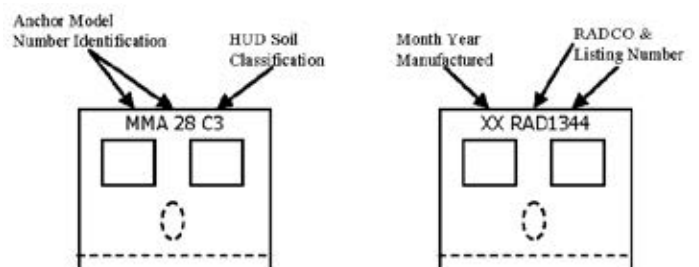

Table 1: Properties of Ground Anchors

Model	Shaft Diameter	Shaft Length (in)	Helix	Minimum Stabilizer Device (See Note 2)
MMA-2 650 DH	5/8"	48	1 / 6" dia	12" plate
MMA-4 650 DH	3/4"	48	1 / 6" dia	12" plate
MMA-6 4430 DH	3/4"	30	2 / 4" dia	12" plate
MMA-28 636 DH	3/4"	33	1 / 6" dia	12" plate
MMA-30 4430 DH	5/8"	30	2 / 4" dia	12" plate
MMA-52 4636 DH	3/4"	33	1 / 4" & 1 / 6" dia	12" plate
MMA-55 4450 DH	3/4"	48	2 / 4" dia	12" plate
MMA-71 1060 DH	3/4"	60	1 / 10" dia	12" plate
MMA-75 760 DH	3/4"	60	1 / 7" dia	17" plate
MMA-85 860 DH	3/4"	60	1 / 8" dia	17" plate
MMA-92 4430 EZDH	3/4"	30	2 / 4" dia	6" cap
MMA-93 4636 EZDH	3/4"	33	1 / 4" & 1 / 6" dia	6" cap
MMA-94 636 EZDH	3/4"	33	1 / 6" dia	6" cap
MMA-96 650 EZDH	3/4"	48	1 / 6" dia	6" cap
MMA-GW2NU	3/4"	20	1 / 4" dia	(See note 3)
MMA-8 48 XDH	3/4"	48	none	X drive (48" rods)
MMA-14 PDH	5/8"	10	none	none
MMA-42S JDH	5/8"	6	none	none
MMA-35 36 XDH	3/4"	30	none	X drive (30" rods)
MMA-35s 36 XDH	3/4"	30	none	X drive (30" rods)
MMA-18 THDH	5/8"	3.5	none	none

Table 2: Soil Anchor Requirements

Model	Minimum Soil Class (See Note 1)	Min. Angle of Pull to Horizontal
MMA-2 650 DH	4a	45 deg
MMA-4 650 DH	4a	45 deg
MMA-6 4430 DH	4a	45 deg
MMA-28 636 DH	3	45 deg
MMA-30 4430 DH	3	45 deg
MMA-52 4636 DH	4a	45 deg
MMA-55 4450 DH	4a	45 deg
MMA-71 1060 DH	4b	45 deg
MMA-75 760 DH	4b	48 deg
MMA-85 860 DH	4b	46 deg
MMA-92 4430 EZDH	3	45 deg
MMA-93 4636 EZDH	4a	45 deg
MMA-94 636 EZDH	3	vertical only
MMA-96 650 EZDH	3	vertical only
MMA-GW2NU	3	45 deg

Table 3: Rock/Concrete Anchor (Soil Class 1) Requirements

Model	Max Test Load (lbs)	Min. Angle of Pull (horiz.)
MMA-8 48 XDH	10,000	vertical only
MMA-14 PDH	5,000	45 deg
MMA-42 JDH	5,000	45 deg
MMA-35 36 XDH	4,725	45 deg
MMA-35s 36 XDH	4,725	45 deg
MMA-18 THDH	5,000	45 deg

Note 1: See 24 CFR Part 3285 Model Manufactured Home Installation Standards, section 202: Soil Classification and Bearing Capacity & Table 3285.202 for an explanation of soil classification numbers. Please note that anchors approved for use in soil class 4 may be used in soil classes 3 or 2, and anchors approved for use in soil class 3 may be used in soil class 2.

Note 2: The stabilizer plates are available in 12" or 17" width. The stabilizer caps are 6" diameter. "X drive" refers to cross-driven anchors which utilize two rods angled at 45 degrees from the vertical.

Note 3: Anchor model MMA-GW2NU has a 6" stabilizer cap as well as a 32" long stabilizer rod which is driven through the stabilizer cap and downward at 45 degrees from the horizontal.



Twining Consulting Inc.
dba. RADCO.

18071 Mt. Washington St.,
Fountain Valley, CA
92708

Tel: (562) 272-7231
Fax: (562) 529-7513

LISTING
RAD#1350

LISTING & TESTING DIVISION

PRODUCT: MANUFACTURED HOUSING SUPPORT PIERS

Issued: Jan. 2014
Reissued: Jan. 2022

MANUFACTURER: Minute Man Anchors
305 W. King St.
East Flat Rock, NC 28726

Subject to Renewal:
January 2023

PLANT LOCATION: 305 W. King St.
East Flat Rock, NC 28726

APPLICATION: HUD Code Manufactured Homes, Modular Homes, and Industrialized Commercial Structures

1. INTRODUCTION

At the request of Minute Man Anchors, RADCO has examined steel piers designed to provide support for HUD Code Manufactured Homes, Modular Homes, and Industrialized Commercial Structures.

2. DESCRIPTION

The standard steel piers have adjustments for placement under the longitudinal I-beams of the manufactured home, modular or commercial engineered structures that range in vertical height from 8 to 30 inches, in 2-inch increments. Steel Piers with vertical height between 22 and 30 inches are reinforced with four (4) 14 Gauge (44 in) x 1 1/4" wide steel straps with the upper edge of the strap located a minimum 11 inches from the top of the pier head. The piers have four legs constructed of 1-inch wide 90-degree angle steel with an average thickness of 0.13 inches. All piers have a rated working load of 6,000 pounds, which is based on a minimum ultimate load of 18,000 pounds. The legs are connected to steel base plate strips. All components of the pier are to be welded, except for the adjustable pier head. Steel conforms to ASTM A-36.

3. INSTALLATION

The application of standard piers is for use on HUD code manufactured homes, modular homes and industrialized commercial structures in engineered foundation systems. The system shall be installed in accordance with the manufacturer's installation instructions and the requirements of this listing for maximum soil capacities as required by section 24 CFR § 3285 of the HUD Standards for Manufactured Housing, IRC Appendix E, Sections AE502, AE601, AE602, AE604 and AE605, to the IBC 2015 and 2018 for commercial use. Other applicable Engineered Connections for Modular and Industrialized Building Systems in engineered foundation systems which will not exceed the product designs.

4. EVIDENCE SUBMITTED

- a) Structural test reports and design drawings and specifications were submitted to substantiate the load carrying capacity of the product and are on file with RADCO.
b) The quality and process control used in the manufacturing and assembly of the product have been submitted to, reviewed, and are on file with RADCO.
c) RADCO's audit inspection program for standard piers is to assure that the product is manufactured from the specified material and in conformance to RADCO's listing and the approved quality control manual.

5. RECOMMENDATIONS

RADCO recommends that Minute Man Anchors standard steel piers be accepted for use in HUD code manufactured homes, modular homes, industrialized commercial structures in engineered foundation systems provided that:

- 1. The product is manufactured at the facility referenced in this listing.
2. Quality control of the product is maintained by the manufacturer.
3. The manufacturing audit and monitoring system by RADCO is maintained in good standing.
4. Each standard pier will be marked with a label, a sample of which is shown in figure 1. The label denotes the RADCO name, and Listing #1350.

6. APPROVAL

This listing is subject to approval on an annual basis by RADCO.

All products shall be identified as follows:

Figure 1: Sample Label

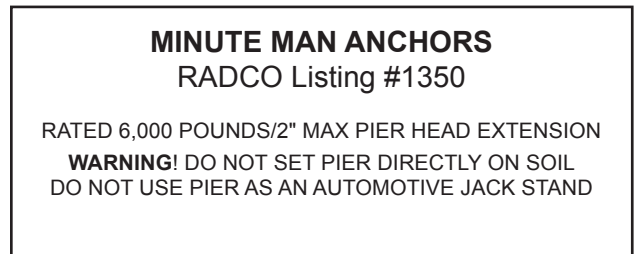

Pier Bottom Stamp



*The first set of X's will represent the pier height and the second set of X's will represent the date of manufacture



Twining Consulting Inc.
dba. RADCO.

18071 Mt. Washington St.,
Fountain Valley, CA
92708

Tel: (562) 272-7231
Fax: (562) 529-7513

LISTING RAD#1355

LISTING & TESTING DIVISION

PRODUCT: SEDCO FOUNDATION BASE PAD

Issued: Jan. 2015
Revised: March 2022

MANUFACTURER: Sedco Pier, Inc.
33320 Mission Trail
Wildomar, CA 92595

Subject to Review:
March 2023

PLANT LOCATION: Harrison Manufacturing -
545 Ford Ave., Jackson, MS 39209

CATEGORY: DESIGN - FOUNDATION BASE PADS

APPLICATION: HUD Code Manufactured & Modular Homes, and Industrialized Commercial Structures

SECTION 1: INTRODUCTION

At the request of Sedco Pier, Inc., **RADCO** has examined their Base Foundation Pads to determine the design load capacity in accordance with Section 3280.401(b) of The Federal Manufactured Home Construction and Safety Standards, as well as Modular Homes, and Industrialized Commercial Structures.

SECTION 2: DESCRIPTION

The Base Pads are molded Base pads having continuous ribs running parallel and diagonal with the pad sides. The Base pads may be used to distribute concentrated pier loads to underlying soil for manufactured housing constructed in accordance with The Federal Manufactured Home Construction and Safety Standards 24 CFR Part 3280. The Base pads are available in various sizes as noted in Table 1.

SECTION 3: APPLICATION AND INSTALLATION

The Base pads shall be installed in accordance with the manufacturer's installation instructions, and the requirements of this listing for maximum soil capacities required by section 24 CFR § 3285 of the HUD Standards for Manufactured Housing, IRC Appendix E, Sections AE502, AE601, AE602, AE604 and AE605, to the IBC 2015 and 2018 for commercial use. Other applicable Engineered Connections for Modular and Industrialized Building Systems in engineered foundation systems which will not exceed the product designs. The maximum design concentrated loads are provided in Table 1.

SECTION 4: EVIDENCE SUBMITTED

- Test Report by RADCO, RAD-5628, January 2015.
- Test Report by RADCO, RAD-5629, January 2015.
- Test Report by RADCO, RAD-5643, February 2015.
- Test Report by RADCO, RAD-5664, March 2015.
- Test Report by RADCO, RAD-5681, May 2015.

SECTION 5: RECOMMENDATIONS

RADCO recommends that the Base Pads be accepted for use of Base Pads pads in bearing capacity of soils listed in Table 1 for support of concrete masonry unit piers, provided that:

- Each Base pad shall be fabricated, identified and installed in accordance with this listing, the manufacturer's published installation instructions, and the applicable code(s). In the event of a conflict between the manufacturer's published installation instructions and this listing, this listing shall govern. The installation instructions shall be available at the point of installation.
- Each Base pads shall be marked with manufacturer name and address, product name, RADCO name/logo and Listing #1355.
- The Base pads are of the same quality and size as tested by RADCO, Inc.
- Piers are limited to steel piers or single or double stacked concrete masonry unit blocks of this listing. These Base Pads have not been evaluated for multiple story building construction.
- The design pier load must not exceed the lesser of the pad capacity, soil capacity or pier capacity. Frost line requirements are not part of this evaluation and shall be governed by State and Local authorities.
- The home or building installer is responsible for the foundation design of each home or industrialized building.
- The manufacturing plant monitoring audit and testing program must continue at the prescribed frequency as mutually agreed upon.

SECTION 6: APPROVAL

This listing is subject to Engineering Review and Approval on an annual basis by Twining Consulting, Inc. dba. **RADCO**. Updating of data and further information may be requested and will be submitted as necessary.

Table 1: Maximum Design Load Capacity for Base Pads

Model	Base Pad Size	Soil Bearing Capacity*			
		1,000 psf	1,500 psf	2,000 psf	3,000 psf
BP 1616	16" x 16"	1,778	2,667	3,556	5,333
BP 1818	18.5" x 18.5"	2,377	3,565	4,753	7,130
BP 1723	17" x 23"	2,726	4,090	5,453	8,179
BP 2020	20" x 20"	2,778	4,167	5,556	8,333
BP 2424	24" x 24"	4,000	6,000	8,000	12,000

*Concrete blocks are rated at 8,000 lbs. Base foundation pads must be double blocked for loads greater than 8,000 lbs up to 12,000 lbs and limited to 10,000 lbs for steel piers.

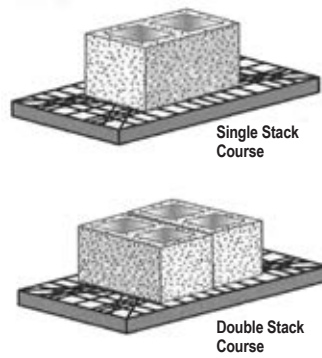

Figure 1 Single and Double Stack Course

MINUTE MAN ANCHORS, INC.

305 WEST KING STREET
EAST FLATROCK, NC 28726
PH: (800) 438-7277

ENGINEERED TIE DOWN SYSTEM

DESIGN & GENERAL NOTES

DESIGN LOADS:

* WIND _____ 15 PSF (70 MPH EXPOSURE "C") CAC T-25 and COMPLIES WITH THE 2019 CBC
Vult = 110 MPH EXP "C" AND THE 2018 IBC Vult = 115 MPH EXP "C"

* SOIL BEARING _____ 1500.PSF

* TIE DOWN STRAP _____ 3150# WORKING LOAD

* SEISMIC _____ CAC T-25 AND 2019 CBC. $S_s=1.5$ $F_a=1.4$ $S_{DS}=1.41$ Site Class D
TIE DOWN STRAPS TO BE MIN. 1 1/4" WIDE x 0.035 THICKNESS ZINC PLATED AND MEET ASTM D-395391

EARTH AUGERS.....3150# (tested to 4725# min) CROSS DRIVES (soil) .. 1575# Stabilizer Plate Required

CROSS DRIVES (asphalt) ...1800# (tested to 3600#) asphalt min 2.5" thick

CROSS DRIVES (solid rock) ..3150# (tested to 4725# min)

CONCRETE SLAB ANCHORS....3150# (tested to 4725# min) drill proper size pilot hole min 4" from any edge

GENERAL NOTES:

1. THE CHARTS SHOWN HEREIN ARE FOR THE REQUIRED NUMBER OF TIE DOWNS ON THE SIDES OF THE MANUFACTURED HOME.
2. TIE DOWNS ARE REQUIRED AT EACH CHASSIS BEAM, EACH END OF EACH TRANSPORTABLE SECTION OF THE MANUFACTURED HOME AND CAN BE ANY OF THE TYPES SHOWN HEREIN.
3. COMBINATIONS OF THE DIFFERENT TYPES OF TIE DOWNS CAN BE USED.
4. IN THE EVENT AN EARTH AUGER CANNOT BE INSTALLED DUE TO AN OBSTRUCTION, USE OF CROSS DRIVE ANCHORS IS PERMITTED, PROVIDED (2) CROSS DRIVES ARE INSTALLED FOR EACH EARTH AUGER THAT CANNOT BE INSTALLED.
5. FOR ALL TIE DOWN INSTALLATIONS, THE MFG'D HOME CHASSIS MEMBERS ARE SHOWN AS "I" BEAMS. FOR ILLUSTRATION PURPOSES ONLY. CHASSIS BEAMS CAN ALSO BE "C" SHAPED OR "RFC" SHAPED.
6. END TIE DOWNS CAN BE LOCATED WITHIN 24" OF EITHER SIDE OF CHASSIS BEAM AXIS AS SHOWN.

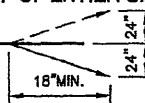

7. THE SIZES, TYPES, LENGTHS, ECT. OF MATERIAL SHOWN HEREIN ARE MINIMUM. LARGER, LONGER, HEAVIER MATERIALS SUPPLIED BY MINUTE-MAN PRODUCTS. MAY BE USED AT THE SAME SPACING & LOCATION SHOWN.
8. ALL PARTS ARE STAMPED MMA- WITH THE APPROPRIATE PART NUMBER.
9. THIS TIE DOWN SYSTEM CAN BE USED WITH 10' WIDE MANUFACTURED HOME SECTIONS WITH 100" CHASSIS CENTERS PROVIDED THE HEIGHT FROM GRADE TO THE BOTTOM OF THE CHASSIS-BEAM DOES NOT EXCEED 19".
10. TIE DOWN STRAPS IN THE LONGITUDINAL OR TRANSVERSE DIRECTION CAN BE BOLTED TO THE HITCH ATTACHMENT PLATE THAT IS WELDED TO THE CHASSIS BEAM.

REV 8-10-09

ENGINEER APPROVAL

SEE PAGE "2" FOR LISTING INFORMATION

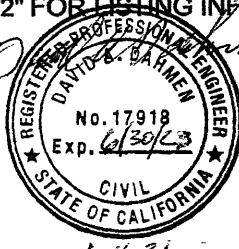

1-4-21

PACIFIC CONSULTING ENGINEERS
9739 North Vista Drive
Kingman, AZ 86401
(916) 296-7376

STATE APPROVAL

ENGINEERED TIEDOWN SYSTEM
APPROVED

Approved does not authorize or approve any omission or deviation from requirements of applicable State laws and regulations.

State of California
Department of Housing and Community Development
DIVISION OF CODES AND STANDARDS

By  Date 1/11/21
(Signature)

SPAN NO. ETS 119

This Plan Approval Expires 2/23/23

PAGE 1 of 4

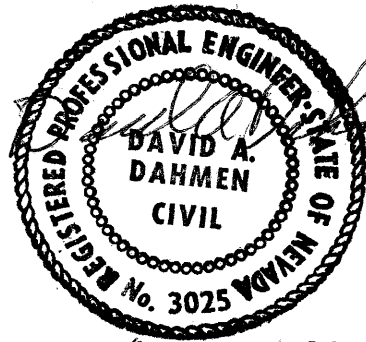
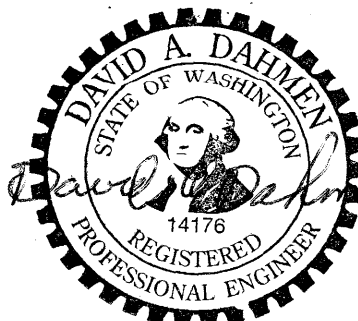
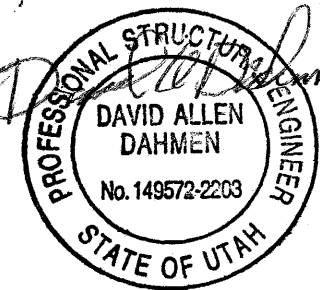
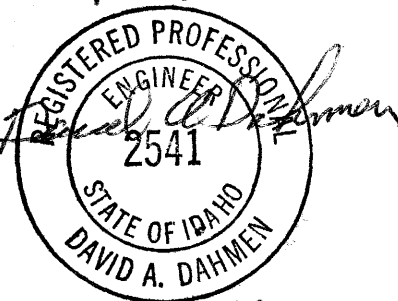
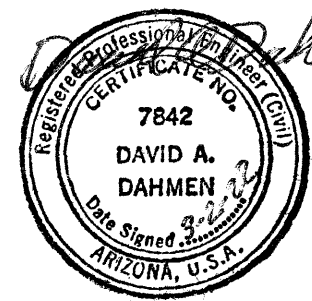
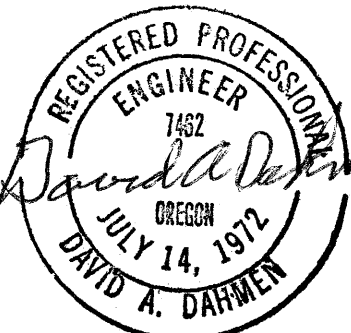

MINUTE MAN ANCHORS

305 WEST KING STREET
EAST FLATROCK, NC 28726
PH: (800) 438-7277

ENGINEERED TIE DOWN SYSTEM DESIGN & GENERAL NOTES

DESIGN LOADS:

- *WIND-----15 PSF (70 MPH EXPOSURE "C") CAC T-25 and COMPLIES WITH THE 2019 CBC
Vult = 110 MPH EXT "C" AND THE 2018 IBC Vult = 115 MPH EXP "C"
- *SOIL BEARING-----1500 PSF
- *TIE DOWN STRAP-----3150# WORKING LOAD
- *SEISMIC-----CAC T-25 AND 2019 CBC. $S_s=1.5$ $F_a=1.4$ $S_{ds} 1.41$ Site Class D
- TIE DOWN STRAPS TO BE MIN. 1 1/4" WIDE X 0.035 THICKNESS ZINC PLATED AND MEET ASTM D-395391
- EARTH AUGERS-----3150# (tested to 4725# min) CROSS DRIVES (soil)---1575# Stabilizer Plate Required
- CROSS DRIVES (asphalt)---1800# (tested to 3600#) asphalt min 2.5" thick
- CROSS DRIVES (solid rock)---3150# (tested to 4725# min)
- CONCRETE SLAB ANCHORS---3150# (tested to 4725# min) drill proper size pilot hole min 4" from any edge

GENERAL NOTES:

1. THE CHARTS SHOWN HEREIN ARE FOR THE REQUIRED NUMBER OF TIE DOWNS ON THE SIDES OF THE MANUFACTURED HOME.
2. TIE DOWNS ARE REQUIRED AT EACH CHASSIS BEAM, EACH END OF EACH TRANSPORTABLE SECTION OF THE MANUFACTURED HOME AND CAN BE ANY OF THE TYPES SHOWN HEREIN.
3. COMBINATIONS OF THE DIFFERENT TYPES OF THE TIE DOWNS CAN BE USED.
4. IN THE EVENT AN EARTH AUGER CANNOT BE INSTALLED DUE TO AN OBSTRUCTION, USE OF CROSS DRIVE ANCHORS IS PERMITTED, PROVIDED (2) CROSS DRIVES ARE INSTALLED FOR EACH EARTH AUGER THAT CANNOT BE INSTALLED.
5. FOR ALL TIE DOWN INSTALLATIONS, THE MFG'D HOME CHASSIS MEMBERS ARE SHOWN AS "I" BEAMS. FOR ILLUSTRATION PURPOSES ONLY. CHASSIS BEAMS CAN ALSO BE "C" SHAPED OR "RFC" SHAPED.
6. END TIE DOWNS CAN BE LOCATED WITHIN 24" OF EITHER SIDE OF CHASSIS BEAM AXIS AS SHOWN.



7. THE SIZES, TYPES, LENGTHS, ETC. OF MATERIAL SHOWN HEREIN ARE MINIMUM. LARGER, LONGER, HEAVIER MATERIALS SUPPLIED BY MINUTE-MAN PRODUCTS MAY BE USED AT THE SAME SPACING & LOCATION SHOWN.
8. ALL PARTS ARE STAMPED MMA- WITH THE APPROPRIATE PART NUMBER.
9. THIS TIE DOWN SYSTEM CAN BE USED WITH 10' WIDE MANUFACTURED HOME SECTIONS WITH 100" CHASSIS CENTERS PROVIDED THE HEIGHT FROM GRADE TO THE BOTTOM OF THE CHASSIS BEAM DOES NOT EXCEED 19".
10. TIE DOWN STRAPS IN THE LONGITUDINAL OR TRANSVERSE DIRECTION CAN BE BOLTED TO THE HITCH ATTACHMENT PLATE THAT IS WELDED TO THE CHASSIS BEAM.

ENGINEER APPROVAL
SEE PAGE "2" FOR LISTING INFORMATION

David C. Dahmen

1-4-21

PACIFIC CONSULTING ENGINEERS
9739 North Vista Drive, Kingman, AZ 86401
PH. (916) 296.7376

STATE APPROVAL
ENGINEERED TIEDOWN SYSTEM
APPROVED

Approved does not authorize or approve any omission or deviation from requirements of applicable State laws and regulations.

State of California
Department of Housing and Community Development
DIVISION OF CODES AND STANDARDS

By *[Signature]* Date 1/11/21
(Signature)

SPANO ETS 119

This Plan Approval Expires 2/23/23

INSTALLATION INSTRUCTIONS

FIRST CHECK FOR UNDERGROUND UTILITY LOCATION:

EZDH EARTH AUGERS

1. SEE DETAIL THIS BOOKLET FOR INSTALLATION INSTRUCTIONS.

EARTH AUGERS

1. INSTALL AUGERS INTO SOIL WITH CONSTANT DOWNWARD PRESSURE TO MINIMIZE SOIL DISTURBANCE LEAVING APPROX. 12" OF SHAFT EXPOSED.
2. INSTALL STABILIZER PLATE - DRIVE FLUSH WITH GROUND SURFACE.
3. COMPLETE TURNING AUGER INTO GROUND UNTIL AUGER HEAD IS FLUSH WITH GROUND SURFACE AND TOP OF STABILIZER PLATE.

CROSS DRIVE ANCHORS

1. CROSS DRIVES ARE USED WHERE HARD ROCKY SOIL OCCURS. IF THE GROUND SURFACE IS OTHER THAN ROCK OR MIN 2.5" ASPHALT, INSTALL MMA-SD2 STABILIZER PLATE, OR PLACE 12"x12"x12" DEEP CONCRETE.

CONCRETE SLAB ANCHORS

1. CONCRETE SLAB TO BE MINIMUM 3 1/2" THICK AND IN GOOD CONDITION.
2. MINIMUM SLAB AREA REQUIRED FOR EACH ANCHOR IS 28 SQ. FEET.
3. DRILL PROPER SIZE HOLE IN SLAB MINIMUM 4" FROM ANY EDGE.

ALL APPLICATIONS

1. ATTACH STRAPS TO CHASSIS BEAM IN MANNER SHOWN.
2. INSERT STRAP THROUGH SPLIT NUT, CUT OFF EXCESS STRAP AND TIGHTEN UNTIL SNUG.

THIS PLAN MAY BE USED FOR MANUFACTURED HOMES PLACES IN FEMA FLOOD HAZARD ZONES A, AE & AH, PROVIDED THE GROUND ANCHORS ARE THE MMA-650, 50" EARTH AUGERS. UNDER FLOOR VENTS AT THE PERIMETER SKIRTING SHALL BE PLACED WITH THE BOTTOM OF THE VENT MAX 12" ABOVE THE UNDER FLOOR GROUND SURFACE

TIE DOWN LOCATIONS

ETS 119
HCD
Exp 2/23/23

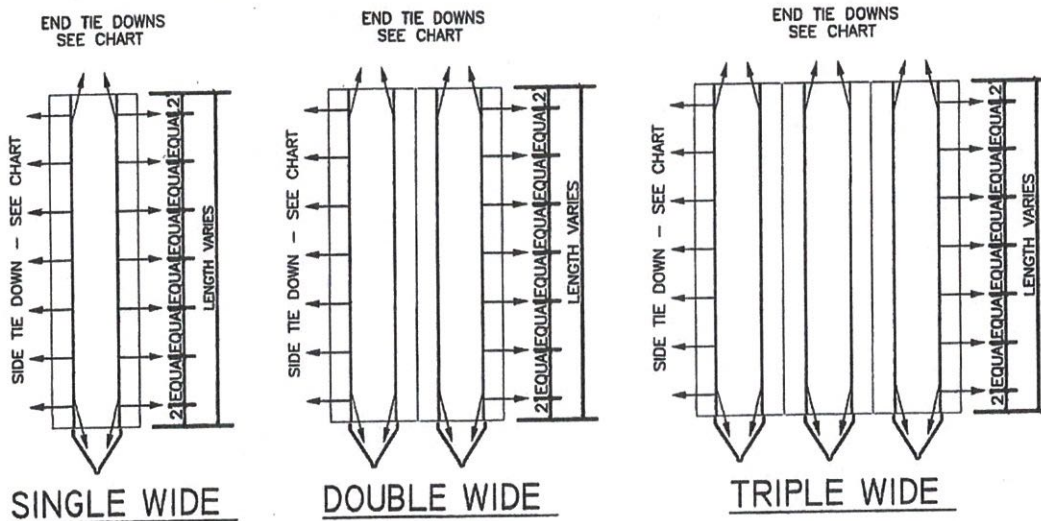

EARTH AUGERS						CROSS DRIVE ANCHORS					CONCRETE SLAB ANCHORS						
MAX. LENGTH OF MFG'D HOME	32'	42'	52'	62'	73'	MAX. LENGTH OF MFG'D HOME	32'	42'	52'	62'	73'	MAX. LENGTH OF MFG'D HOME	34'	42'	50'	59'	68'
MAX. NO. OF SIDE TIE DOWNS	3	4	5	6	7	MAX. NO. OF SIDE TIE DOWNS	3	4	5	6	7	MAX. NO. OF SIDE TIE DOWNS	4	5	6	7	8

NOTE: IF OBSTRUCTIONS PRECLUDE THE PLACEMENT OF THE SIDE TIE DOWNS AT THE 2' LOCATION SHOWN SIDE TIE DOWNS AT 2'-0" FROM EACH END HAVE A TOLERANCE OF 1±

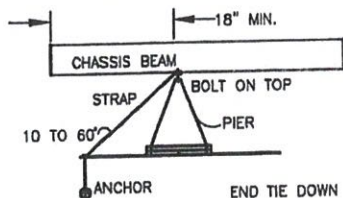

MINIUTE MAN PRODUCTS
LISTED BY: **RADCO**
3220 E. 59th Street
Long Beach, CA 90805
LISTING NUMBER AT .1344
TIE DOWN SYSTEM TO BE IDENTIFIED BY A STICKER PLACED ON THE STEEL STRAPS MM-32 OR MMA-71 - STICKER TO CONTAIN THE FOLLOWING.
MINIUTE MAN PRODUCTS ETS-119
RADCO
Listing Number 1344

NOTE: TIE DOWN STRAPS AT THE CHASSIS BEAM ENDS (END TIE DOWNS) CAN BE ATTACHED TO A CHASSIS SUPPORT PIER WITH A PIER BOLT ON TOP. (SEE SKETCH ABOVE).

"I" BEAM SHOWN, SEE
"C" & "RFC" CHASSIS FOR
END TIE DOWN CONNECTIONS

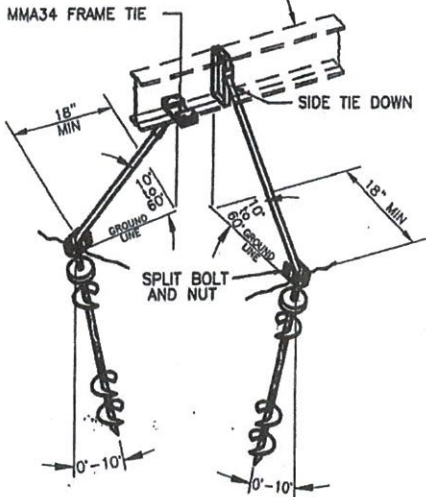

NC4636, EZDH & MMA34
EARTH AUGER TIE DOWN

"I" BEAM SHOWN, SEE
"C" & "RFC" CHASSIS FOR
END TIE DOWN CONNECTIONS

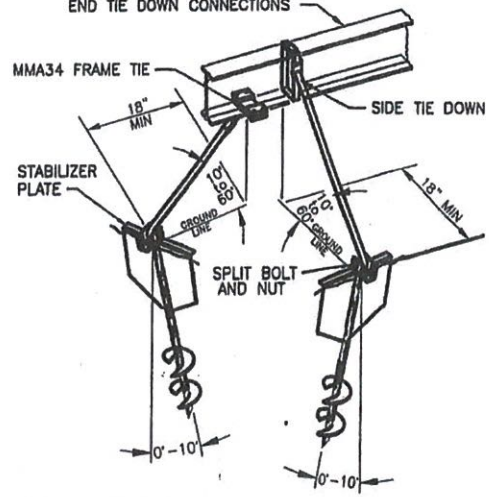

EARTH AUGER TIE DOWN

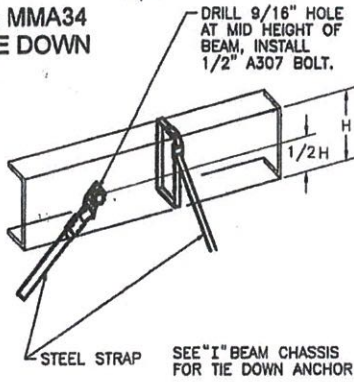

"C" BEAM CHASSIS

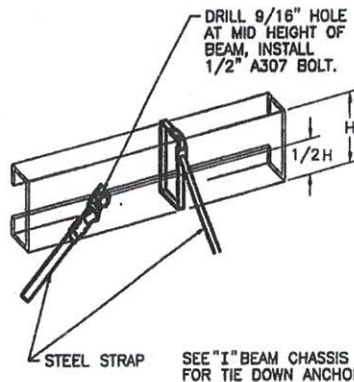

"RFC" BEAM CHASSIS

ETS 1/19
HCD
Exp 2/23/23

INSTALLATION INSTRUCTIONS

1. THE DRIVE MACHINE IS STARTED AND THE ANCHOR IS TURNED INTO THE GROUND TO A POINT WHERE THE TOP (STABILIZER HEAD PLATE) IS FLUSH OR SLIGHTLY BELOW GROUND LEVEL. THIS INSURES THAT THE E-Z ANCHOR STABILIZER WILL BE AT ITS REQUIRED INSTALLATION POSITION.
 2. FOR THE E-Z ANCHOR/STABILIZER TO ACHIEVE FULL POTENTIAL, INSTALL THE ANCHOR VERTICALLY WITH NO DEVIATION GREATER THAN 10 DEGREES. NOTE: A SLIGHTLY GREATER ANGLE MAY BE USED TO START THE ANCHOR TO AVOID CONTACT WITH THE HOME & STRAIGHTENED AS THE ANCHOR IS GROUND SET. THE SPLIT BOLT IS INSERTED, STRAP FASTENED, AND TIGHTENING ADJUSTMENT MADE.
- NOTE: WITH MACHINE INSTALLATION, A MINUTE-MAN ADAPTER DESIGNED TO FIT BOTH THE ANCHOR HEAD AND DRIVE MACHINE SHAFT IS AVAILABLE. INSTALLERS DO NOT NEED ADDITIONAL OR SPECIAL EQUIPMENT FOR E-Z ANCHOR INSTALLATION.

CONCRETE TIE DOWN

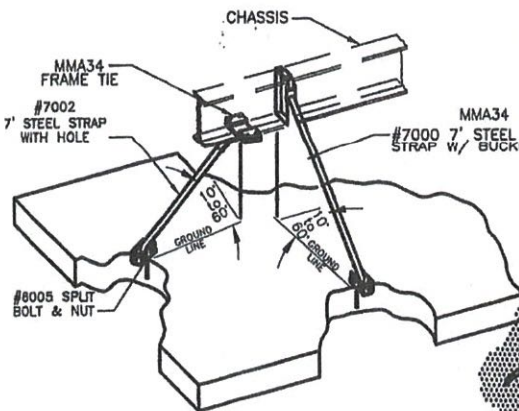

CROSS DRIVE TIE DOWN

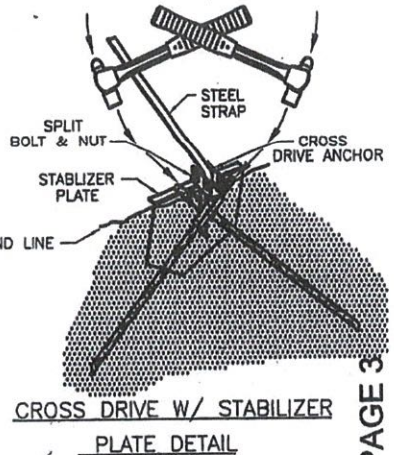
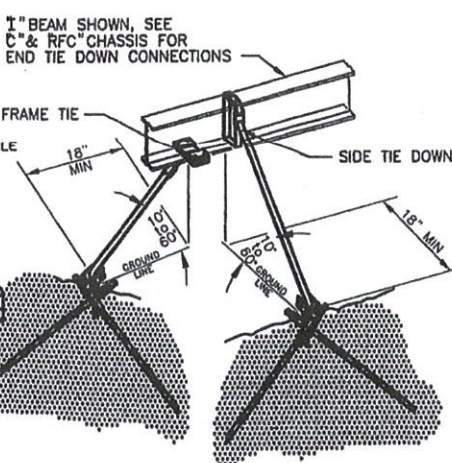

CROSS DRIVE W/ STABILIZER
PLATE DETAIL

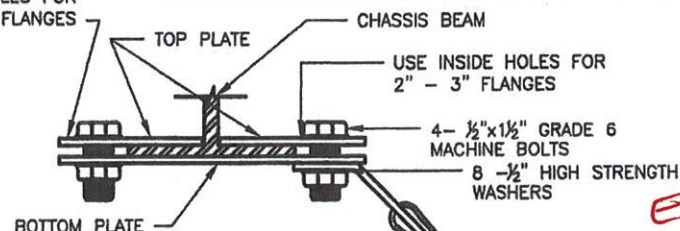
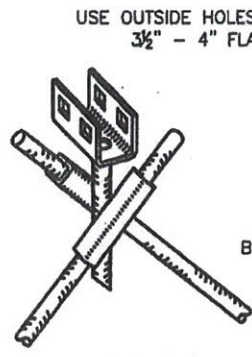
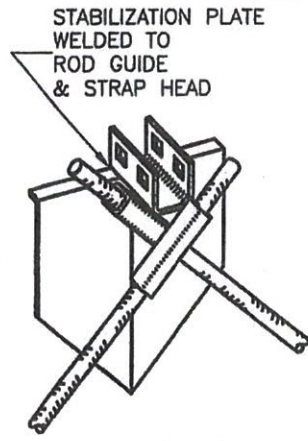
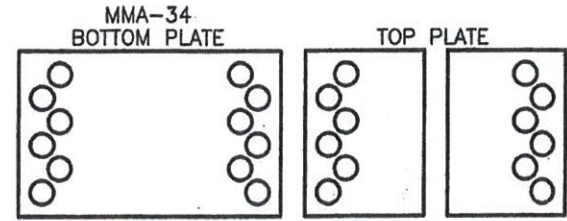
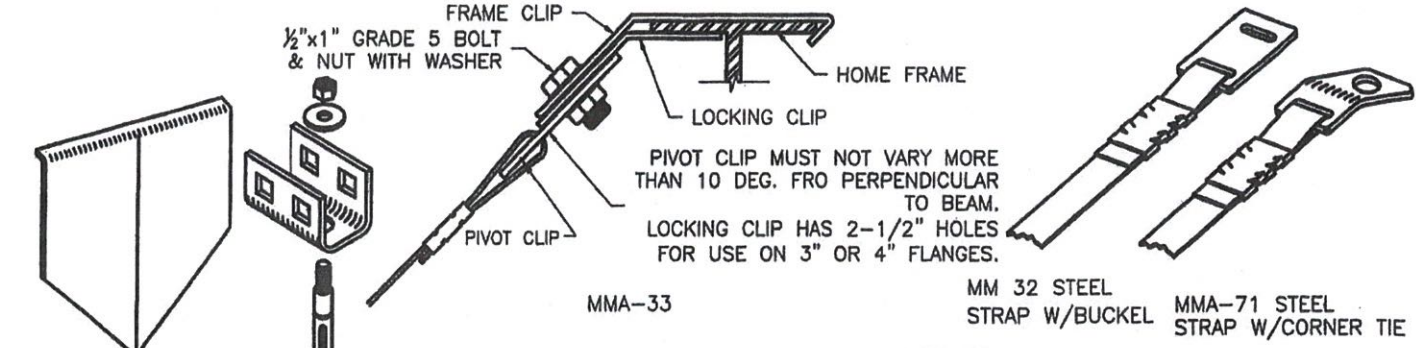

ETS 119
 HCD
 Exp 2/23/23

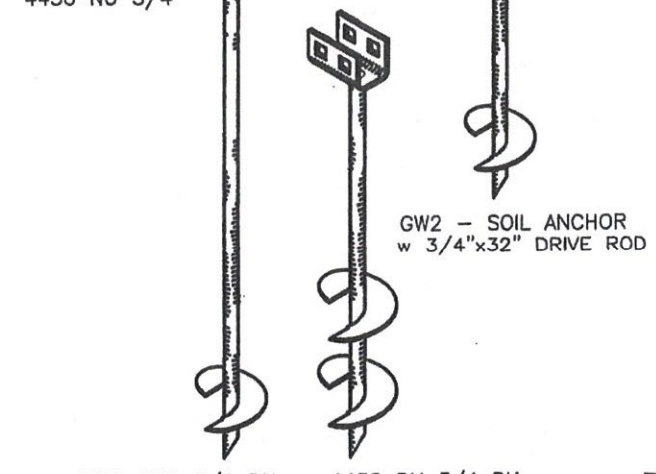
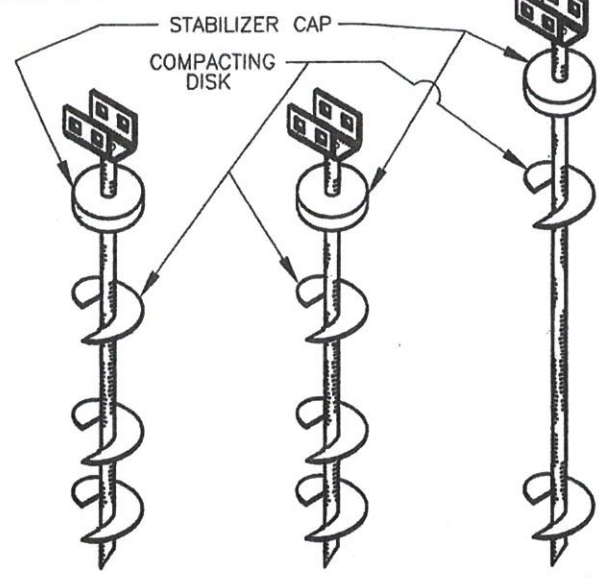
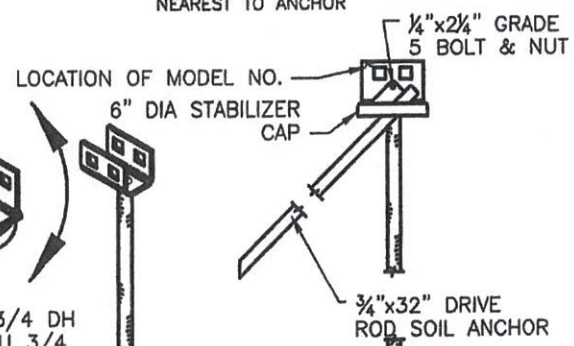
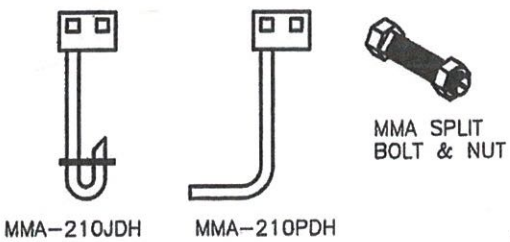
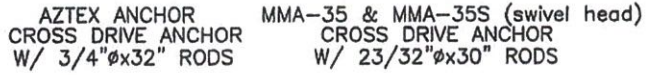

LONGITUDINAL AND LATERAL BRACING SYSTEM

LONGITUDINAL BRACE DETAIL

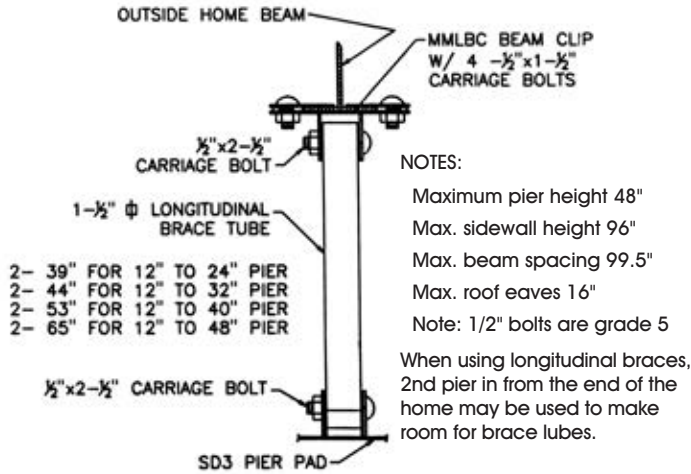

LATERAL BRACE DETAIL

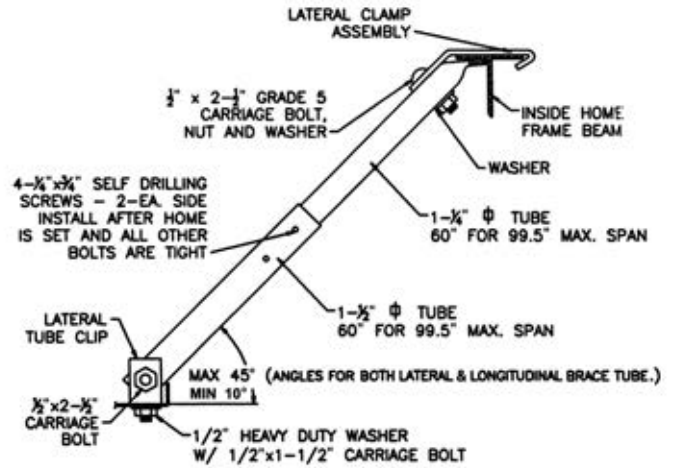

LONGITUDINAL BRACE FLEX TUBES FOR CONCRETE

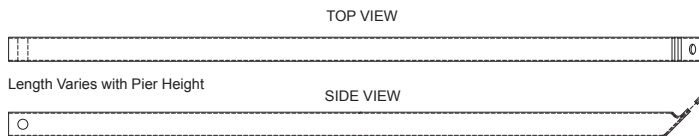

LATERAL BRACE FLEX TUBES FOR CONCRETE

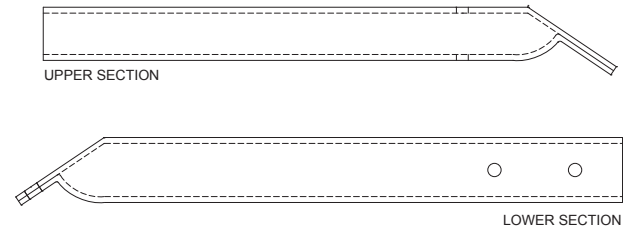

LONGITUDINAL & LATERAL BRACING SYSTEM DETAIL ASSEMBLY DRAWING

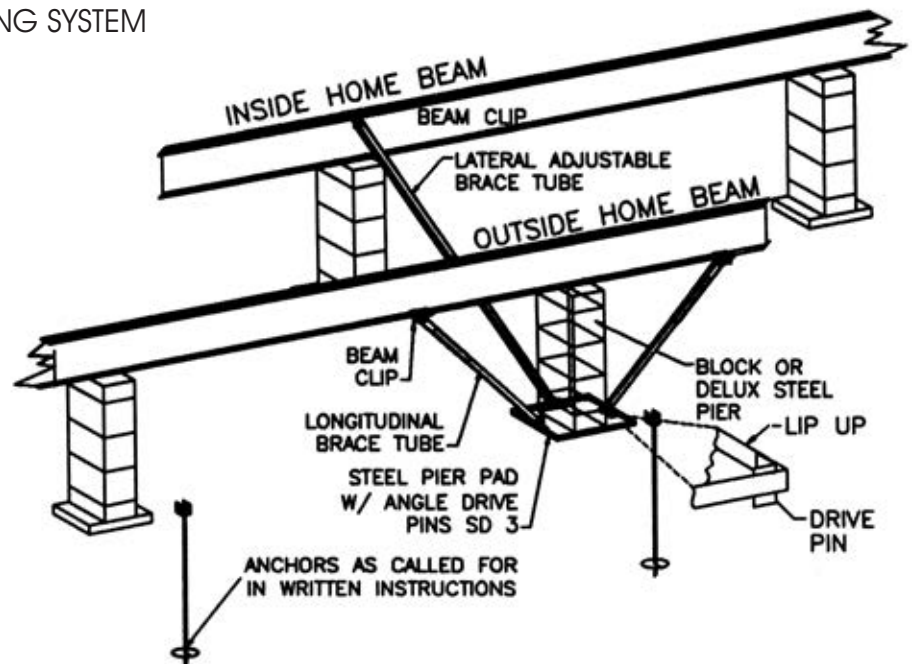

The Minute Man Anchors LLBS Bracing System was tested for Wind Zones I, II, & III
Tested 10/10/01
Rev. 3/6/02
Rev. 7/14/04
Rev. 2/1/10

NOTE:

All LLBS Systems are shipped with complete installation instructions.
See these instructions for System Locations in Zones I, II, III, FL.

“SUGGESTED RECOMMENDATIONS WHEN USING CRIMPING SEALS”

1. The strap must be identified “MINUTE MAN ANCHORS **CERTIFIED ANSI 225.1 AND ASTM D3953.**”
2. WHEN EXTENDING OR SPLICING TWO STRAPS, OVER LAP APPROX. 6", USE TWO SEALS FULLY CRIMPING EACH SEAL TWICE TO BOTH STRAPS.
3. WHEN STRAPPING TO AN APPLIANCE SUCH AS SLOT IN A VERTICAL TIE OR A HOOK OR A BUCKLE WE SUGGEST THAT YOU USE A SHORT PIECE OF STRAP (RADIUS CLIP) BENT 180 degrees IN DIRECT CONTACT WITH THE APPLIANCE. (This will act as a cushion, reinforce and prevent sharp bends in the strap.) NEXT INSERT THE STRAP BENDING IT OVER 180 degrees BACK TO THE STRAP USING ONE SEAL, PLACE BOTH STRAPS INTO SEAL AND CRIMP TWICE.
4. SEALS MUST ALWAYS BE CRIMPED TWICE.
5. PLEASE NOTE: TWO SEALS REQUIRED WHEN SPLICING TWO STRAPS. ONE SEAL WHEN BENDING 180 degrees.

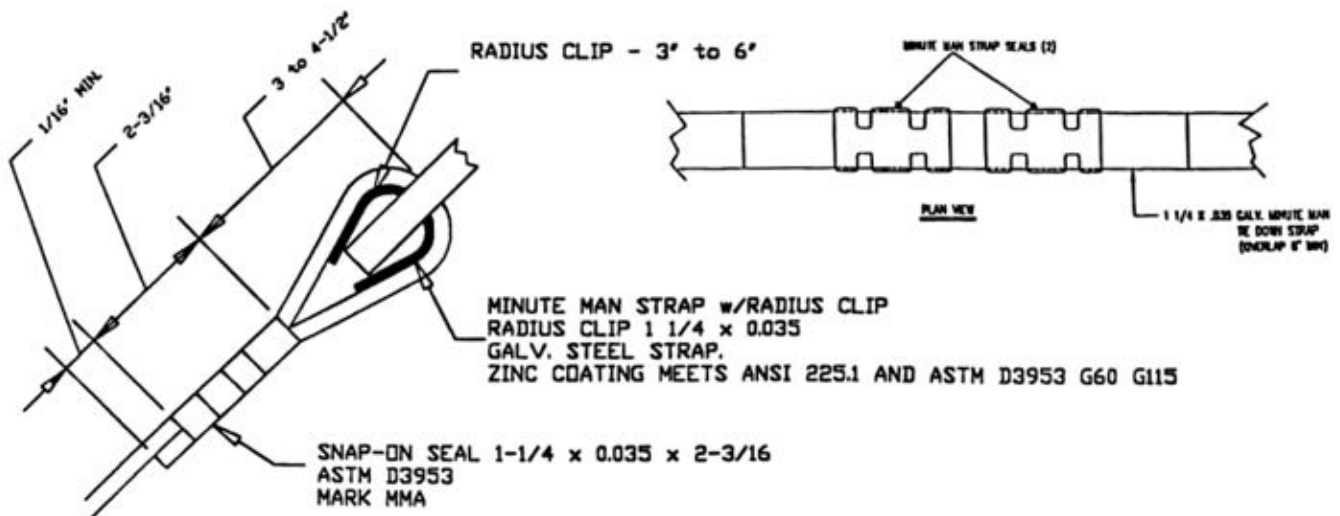

Minute Man Anchors

"Specializing in Anchoring Earth Bound Objects"

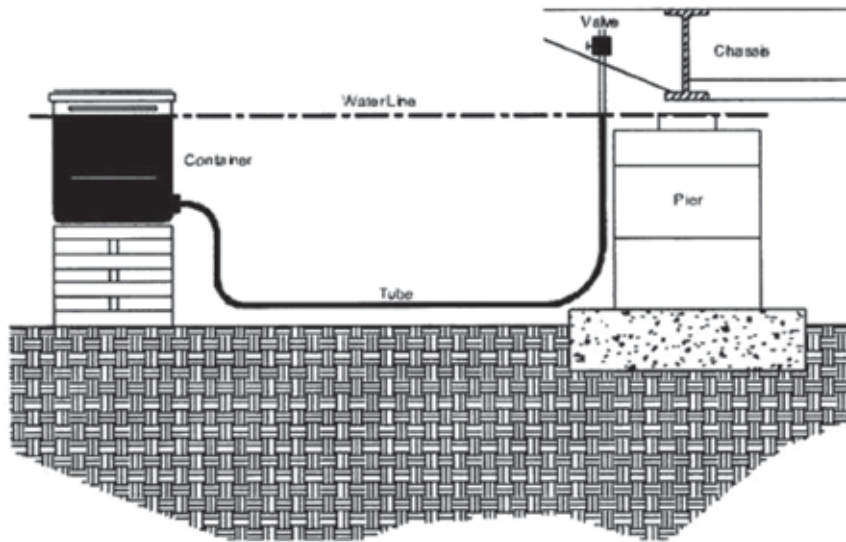

WATER LEVEL Item # 5320

Uses automotive washer fluid, adjustable reservoir, steel post is removable from heavy steel base, magnetized brass valve, allows for easy removal of air bubbles, includes 100' of 1/2" transparent hose for quick leveling.

WATER LEVEL INSTRUCTIONS

Step 1: *There cannot be any bubbles in the line for the water level to be accurate.* Procedure to bleed out bubbles: Lay the water line out flat, hold the valve below the level of the reservoir, open the valve at the end of the line, bleed out any air bubbles, as the bubbles flow through the line add water to the reservoir until all bubbles are flushed out, next close the valve. **BLUE** automotive washer fluid can be used to prevent freezing and better visibility.

Step 2: Once the structure height is determined, locate level close enough to reach all the pier locations. Clear the area of any objects that may obstruct, snag, or crush the tubing when moving from pier to pier. Open valve and adjust reservoir height until the water level at the valve end lines up with the bottom, I beam flange (*the home frame*). **CLOSE VALVE.**

Step 3: Place valve/magnet on frame with valve closed. **ALWAYS CLOSE VALVE BEFORE YOU PLAN TO MOVE IT.** Adjust the reservoir on the stand so the water level is as close to the bottom level of the frame as possible. Open valve and adjust reservoir height until the water level at the valve end lines up with the bottom plate of the frame. **CLOSE VALVE.**

Step 4: Once you have set the final height adjustment, you are ready to set/level the home

Step 5: Repeat until **all the piers** are at the same level. When complete the structure should be level (*side to side, front to back*). **THIS IS EASIER WITH TWO PEOPLE.**

NEW SETS: Establish where the highest point of the grade is first, set bottle away from the structure, lay out line, and take valve end to the highest point of the grade using a tape measure to adjust the water level at the valve end by adjusting the bottle height to desired minimum frame height. Use a pre-marked 1" x 2" board at the valve end.

**ALWAYS CLOSE VALVE BEFORE RELOCATING AND STORING.
DO NOT ALLOW THE HOSE TO GET KINKED OR PUT HEAVY OBJECTS ON HOSE.
A KINKED OR OBSTRUCTED HOSE WILL ADVERSELY AFFECT THE
FUNCTIONAL ACCURACY OF THE LEVEL.**

Anchor • Drive Anchor • Anchor Kits • Anchor Drive Machines • Strapping • Mobile Home Piers



Eye Anchor



650 DH 5/8, 1 1/16, & 3/4



36" & 48" Cross Drive



EZDH Anchor
4430, 4636
636 & 650
Available



4636 DH 3/4



4430 DH 5/8, 1 1/16, & 3/4

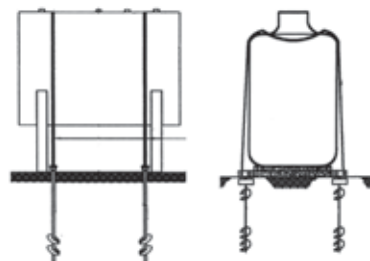

Tank Anchoring Systems



Strap Bolt and Nut



Strap Buckle



Stabilizer Plate

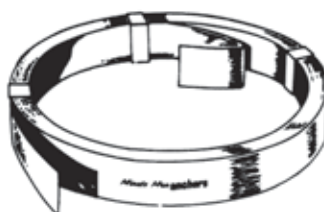

Galvanized Strapping



210JDH



210PDH



THDHL



Standard Pier

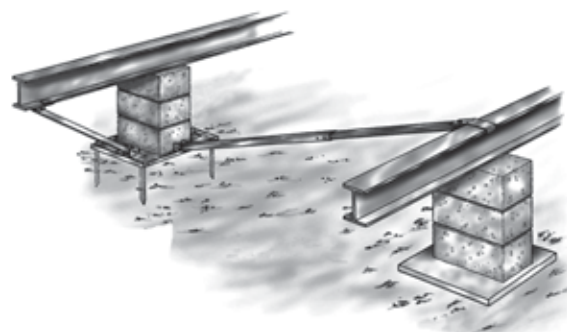

LLBS Foundation Bracing System



Roof Bracket



Buckle W/Strap

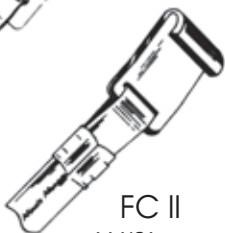

FC II W/Strap



LFC II W/Strap

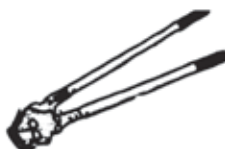

Crimping Tool

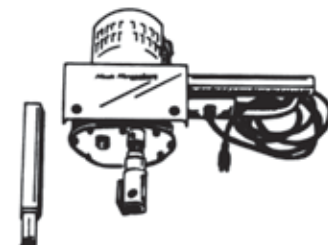

Minute Man Anchors Drive Machine